

KENDRIYA VIDYALAYA SANGATHAN (KVS)



केन्द्रीय विद्यालय संगठन

Guidelines for Planning and Construction of School Buildings of KVS

September 2005
Reprint April 2008
Revised February 2013

* For Internal Circulation only

MESSAGE

The compilation of this kind has been a long felt need as time and again K.V.S. has issued a number of guidelines circulars to enable architects / engineers for effective preparation of plans, estimates and ensure execution of various components of school building and the campus strictly as per guidelines. However over a period of time the copies of these circulars / guidelines are either found misplaced/ not available with the agencies or there are many missing links. Hence an effort has been made to make the guidelines available in hand, in a consolidated form.

The present booklet covers the contents of all earlier circulars / guidelines besides incorporating brief specifications, schedule of fitting / fixture and various other requirements for Vidyalaya buildings and its campus as per actual need. It is believed that this will help not only the architects / engineers for better planning / execution but also Principal of Vidyalaya to cross check the items catered to be provided in the premises, during execution.

Certain provisions covered in the booklet are based on the requirement of our students, the practical experience of Kendriya Vidyalaya Sangathan officers who have inspected the Vidyalayas and interaction / feed back received from various quarters.

There is always a scope for improvement correction. Any suggestions / data correlating with present day scenario particularly in the field of education are most welcome. Discrepancies, if any, may also be pointed out.

Space norms for Kendriya Vidyalayas as on 16.05.2008

teaching/service support/administrative/class rooms

S.No.	Description	No. of rooms and size required as per KVS space norms							
		A-1 Type (single section)		A-Type (two section)		B-Type (three section)		C-Type (four section)	
		Nos.	size in mts	Nos.	size in mts	Nos.	size in mts	Nos.	size in mts
1	Computer Lab	1	7.00 x 7.00	2	7.00 x 10.60	3	7.00 x 10.60	3	7.00 x 10.60
2	Labs	3	7.00 x 8.80 7.00 x 3.60	3	7.00 x 8.80 7.00 x 3.60	3	7.00 x 8.80 7.00 x 3.60	3	7.00 x 8.80 7.00 x 3.60
3	Jr. Sci. Lab					1	7.00 x 10.60	1	7.00 x 10.60
4	Social Sci/Geo/Resource room (Primary)	1	7.00 x 3.40	1	7.00 x 3.40	1	7.00 x 3.40	1	7.00 x 3.40
5	Social Sci/Geo/Resource room (H/Secondary)	1	7.00 x 3.40	1	7.00 x 7.00	1	7.00 x 7.00	1	7.00 x 7.00
6	Activity room	1	7.00 x 10.60	1	7.00 x 10.60	1	7.00 x 10.60	1	7.00 x 10.60
7	Art room	1	7.00 x 7.00	1	7.00 x 10.60	1	7.00 x 10.60	1	7.00 x 10.60
8	SUPW/Workshop	1	7.00 x 7.00	1	7.00 x 10.60	1	7.00 x 10.60	1	7.00 x 10.60
9	Library	1	7.00 x 10.60	1	7.00 x 14.20	1	7.00 x 17.30	1	7.00 x 21.40
10	Maths Lab	1	7.00 x 7.00	1	7.00 x 7.00	1	7.00 x 7.00	1	7.00 x 7.00
11	Principal room	1	7.00 x 7.00	1	7.00 x 7.00	1	7.00 x 7.00	1	7.00 x 7.00
12	Office	1	7.00 x 7.00	1	7.00 x 7.00	1	7.00 x 7.00	1	7.00 x 7.00
13	Staff common room	1	7.00 x 7.00	1	7.00 x 7.00	1	7.00 x 8.80	1	7.00 x 10.60
14	Vice-Principal room					1	3.40 x 3.40	1	3.40 x 3.40
15	Head Master/Head Mistress room			1	7.00 x 3.40	1	7.00 x 3.40	1	7.00 x 3.40
16	Exam. Room	1	7.00 x 3.40	1	7.00 x 3.40	1	7.00 x 3.40	1	7.00 x 3.40
17	NCC/Scout/Guide room	1	7.00 x 3.40	1	7.00 x 7.00	1	7.00 x 7.00	1	7.00 x 7.00
18	PEF room	1	7.00 x 3.40	1	7.00 x 7.00	1	7.00 x 7.00	1	7.00 x 7.00
19	Gen. store	1	7.00 x 3.40	1	7.00 x 7.00	1	7.00 x 7.00	1	7.00 x 7.00
20	Medical room	1	7.00 x 3.40	1	7.00 x 3.40	1	7.00 x 3.40	1	7.00 x 3.40
21	Class room	12	7.00 X 7.00	24	7.00 X 7.00	36	7.00 X 7.00	48	7.00 X 7.00

BRIEF SPECIFICATIONS FOR KENDRIYA VIDYALAYA SCHOOL BUILDINGS

FOUNDATIONS

Bearing capacity 10 tonnes / Sqmt.
Type - Spread foundation - isolated / combined.
Depth - Upto 1.20 mt's below ground level.

SUPERSTRUCTURES

- R.C.C. Framed construction with filler walls in Brick work or Load bearing construction in brick / stone masonry with intermediate columns wherever found necessary.
- Internal partition in Brick Masonary.
 - R.C.C. Chajjas, fins, jails etc.

REMARKS

The design foundation / superstructure shall strictly be subject to soil investigation report of the particular site and incorporating necessary provision for earth quake resistance as per I.S. Codes.

DOOR & WINDOWS

Frames of 2nd class Indian teakwood or equivalent or T-Iron frame, pressed steel frame as per CPWD specifications.

Door shutters - Pannelled type in 2nd class teakwood or flush door with commercial ply as per CPWD specifications.

Window shutters - 2nd class Indian teakwood or steel windows.

The size of glass panes shall be minimum so that replacement of broken ones becomes easy.

Fittings - Anodised.
Aluminium or equivalent.

FLOORING

- Main entrance halls, stair case, lavatory blocks - in situ mosaic / Kota stone / or equivalent.
- Rest of the area including class rooms ordinary cement concrete (1 PS Floor)
- Principal Room - Glazed ceramic tiles of CPWD approved brand.

ROOFING

- Filling for drainage line concrete finish with brick tiles.
- Water proofing treatment - 4 course treatment finished with brick tiles or any other specification as adopted for Govt. buildings locally.

ADDITIONAL DATA/FITTING & FIXTURES FOR SCHOOL BUILDINGS OF KENDRIYA VIDYALAYAS

I.	Class Rooms:-			
		Flooring	-	KOTA or equivalent where kota is not available
		Wall & Ceiling	-	White Wash
		Black Board	-	3.00 Mts x 1.40 Mts (Cement concrete)
		Cup Board	-	1 No. with C.C. racks and Black Board Shutter upto lintel level
		Fans	-	5 Nos(56") including one above teacher
		Tube Lights	-	5 Nos. including one above teacher/Black Board (Single fitting ordinary Hanging type)
		Power Point	-	01 No.
		Pin-up Board	-	As shown in drawing

Note:-

- (i) Raised platform for teaching shall not be provided.
- (ii) Switch Boards/M.C.Bs should be covered in box and shall be provided at lintel level.

I (a) Primary Class Room

- (i) Left hand side of the wall with reference to entry to the class room shall have a two tier shelve with height upto window cill level. Sliding shutter with locks shall be provided.
- (ii) The wall opposite black board, upto window cill level shall be finished properly with green paint and preferably with a band of 2" of yellow colour, so that student can draw figures, sketch etc.

II Labs:-

- Requirement of Fans/Tube lights shall be worked out on proportionate basis.
- For chemistry Lab.,R.C.C. Demo. Tables as per KVS layout shall be provided. In other Labs. Tables are not required.
- Acid proof tiles shall be provided on tables and top of side racks (Chemistry Lab)
- Adequate no. of exhaust fans shall be provided.
- Groove for Gas pipe line shall be made in the floor. The gas connection, including laying of gas pipe line shall be got done by Principal through Govt. Oil companies like HPCL/BPCL/IOC. However on request of Principal gas chamber of required size out side the building shall be constructed as per specifications of oil companies.
- Water supply shall be provided as per requirement.
- Drainage in the form of covered drain shall be provided.
- Provision of Chemistry Lab. Should be made in ground floor only.
- Required number of power points shall be provided in each Lab.

III Principal Room :-

- Attached toilet shall be provided.
- Flooring shall be Glazed ceramic tiles.

Office / Staff Room

Exam. Room / Store

NCC Room

P.E.T. Room

Activity, SUPW Rooms etc.

Built in storage shelves on wall sides with shutters shall be provided as per the pattern, length, height, decided as per architectural drawings.

The wall between two adjacent rooms i.e. Activity/SUPW/Art and a class room or similar size room shall be provided with movable partition for cultural, curriculum activities etc.

IV Computer Room :-

- P.V.C. flooring shall be provided.
- Power points for P.Cs shall be provided as per requirement of Principal.
- Provision for Air Conditioners in window and power points shall be provided. However Air Conditioner shall not be provided.
- Aluminum double door shall be provided for entry door.

V Toilets :

- Adequate no. of W.C., Urinals partitions wash basins etc. shall be provided as per I.S.I. yard sticks.
- No lipped Urinals shall be provided in Boys toilets. Instead a half glazed channel with partitions shall be provided. However squatting plates shall be provided in Girls Toilets.
- Provision of one bath room shall be made in each toilet.
- Exhaust Fans shall be provided.
- White Glazed tiles of 900 mm height in W.C. room and 1800 mm height in the rest of the walls.

VI Corridors / Stair Cases:-

- All corridors / stair cases shall be laid with Kota stone slabs or equivalent.
- Mummy room for stair case to make access to roof top shall be provided.

VII General

- Aluminum door with collapsible shutter shall be provided at the entry of the building.
- For safety precautions all openings, electrical panels, proper enclosures / grills shall be provided.
- Plinth protection around building with plinth drain connecting the main drains in the campus shall be provided. Similarly proper drainage arrangement in the open spaces inside / outside of the building shall also be made so that water do not stagnate in the campus causing hardship to students while play and movement etc.
- Only L.T. connection shall be taken as far as possible in order to avoid huge recurring expenditure on electricity bills.
- Cycle/Scooter stand for 100 /200 nos. with simple truss and A.C sheet roofing shall be provided close to boundary wall near left hand side of main gate (only simple specifications).
- Canteen (Kiosk Type) without sitting space but with cooking, storage and service counter facilities shall be provided at a suitable place in the campus so that entry of outsiders could be restricted.
- Boundary wall for school plot shall be provided. As per KVS norms the height should be 5' - 6' including grill. However, whenever safety problems are there on the written request of Principal, the height shall be increased to 6' including grill. Grill shall be provided only on front side and other sides barbed wire instead of grill shall be provided.
- The width of road from gate to main entry of school building shall be 6.00 Mts. All other internal roads / paths shall be minimum width and as per requirement. However economic and functional layout of internal roads / paths to connect various facilities shall be developed.
- Corner lights at all building corners and street lights parallel to roads / paths shall be provided for proper watch and ward.
- Sign Board (Painted - Not neon) of required size shall be provided at the main gate.
- Cooler spaces with glazed tiles and water supply arrangement and drainage shall be provided at suitable places in the school building as decided by Architect. These spaces shall not be too close to toilets. Coolers shall not be provided.
- In the campus, Drinking Water troughs shall be provided at suitable locations and play areas (Minimum - 2, Maximum - subject to requirement and availability of space / land).
- At least one power point shall be provided in all Admn. / Service - Support rooms.
 - Width of corridor shall be 1800 mm for singly loaded and 2100 mm for doubly loaded.
 - In the academic related rooms(except class room) glass or equivalent writing boards shall be provided.
 - Ramp with suitable width and gradient to all floors, shall be provided as per standards.
 - All open drains shall be covered with pre-cast slabs for student safety and also ease of maintenance.

- ✓ All input materials to be used shall be cost effective and durable. However locally available material/specifications shall be adopted as decided by the Architect to economise in cost.
- ✓ Availability of potable water shall be clearly ascertained. Provision for tube well, U/G sump of adequate capacity, pumps (both submersible/boosters). Pump House etc. shall be taken in the estimate, furnish cost of each component separately. Alternate water supply connection from local Authorities shall also be taken as stand by arrangement.
- ✓ Electric load requirement shall be properly calculated and provision for transformer, laying cables, payment to be made to local Elect. Board etc. shall be included.

In case of Defence Sector, paramilitary forces kendriya vidyalayas water and electricity are to be provided by the sponsoring authority at prescribed rates as per MOD/MHA guidelines. This aspect should be explored through Principal first.

- ✓ While developing master plan clear boundaries of K.V. plot/ plots, proposed facilities viz. School building (making provision to further expansion to next higher type), residential area showing no. of blocks, play fields, cycle stand, canteen, drinking water facilities services, roads/paths drainage, septic tank, soak pit, water supply like tube well, pump house etc. shall be clearly shown, so that over all development is made in planned way.
- ✓ Provision for fire fighting for school building as per bye-laws and NBC guidelines and bye laws of local Fire Services Department shall be made and water harvesting system for structure shall be explored and provided wherever feasible.
- ✓ While planning school building, guidelines and space standards for barrier free built environment for disabled and elderly persons issued by CPWD shall be kept in view and minimum provisions be incorporated.
- ✓ CRZ/AAI guidelines shall be followed while developing the drawings.
- ✓ National Building Code shall be kept in view while developing the drawings.
- ✓ All mandatory approvals shall be taken before start/completion of work. Copies of all approvals including two sets of all drawings (Architectural, structural, services (Civil/Elect) duly approved by local bodies shall be handed over to Principal for his/her record and further reference.
- ✓ Being 'Deposit Work' it is the responsibility of construction agency to obtain all mandatory approvals before start/after completion of work. However Principal will sign the application papers required and extend help/co-operation in this regard.
- ✓ While planning and designing buildings, standard engineers practice should be followed so that the buildings so constructed shall be functioned incurring minimum capital outlay.
- ✓ Economy should be given due consideration at design stage in view of increasing construction cost.
- ✓ Play facilities, site development work shall be provided by taking best advantage of terrain, so as to ensure minimum cutting/filling is involved. The possibilities of stilt level planning shall be explored in hilly terrains. Proper drainage arrangement shall also be made.
- ✓ Ensure designed planning efficiency (ratio of carpet area to plinth area) is achieved.
- ✓ Green building parameters shall be adopted.
- ✓ Proposed school building shall match and blend with local architecture of the area.
- ✓ The building shall be aesthetically pleasing and look like educational building.
- ✓ Local climatic conditions should be considered in order to provide building with thermal comfort and energy efficient/economy.
- ✓ Use of solar energy in the campus shall be explored for lighting of important places to save electrical energy, besides being a demonstration for students of the vidyalaya.
- ✓ A cattle catcher shall be provided at the entrance gate.
- ✓ In typical site conditions, requirement of fitting/fixtures shall be provided to suit the local site conditions.
- ✓ A raised platform/stage for functions, with tubular truss and sheet roofing shall be provided at suitable location.

- Assembly area for accommodating atleast 1000-2000 depending upon requirement of school shall be provided in front of stage.
- A Flag post shall be provided.
- All Switch Boards/MCBs etc. shall be provided at lintel level covered in boxes with lock/key facility. Similarly wherever Electric Main Boards are there in the building or in the campus, the same shall be covered with wire mesh frames and doors.
- Subject to availability of adequate land, school building shall be planned adopting singly loaded to reduce noise levels/distrurbance.
- Height of the room (Floor to ceiling) shall be kept 3500 mtr or as per site requirement and specifications of CPWD/MES.
- Wet areas in school building shall be kept away within the building to prevent seepage in adjacent rooms and foul smell etc.

- Proper location of Tube Well, Pump House, Sump, Septic Tank, elect. transformer etc. shall be decided so that these will not create safety hazards and become obstruction for future expansion of building and other facilities.
- Demarcation walls of low height (about 30-45 cms) with light weight grill (about 60 cms) or wire mesh in order to demarcate various areas and facilities shall be provided.
- A raised platform or stage with tabular truss and GI/AC sheet roof shall be provided for conducting Annual Day / Cultural Activities etc.
- A sentry post of 1.80 X 1.80 Mtrs. shall be provided at entrance gate.
- Garbage bins of suitable size at proper locations shall be provided.
- In-corporate plantation scheme, parks and other horticulture works in the campus in the master plan. However, this will be developed by the Vidyalaya.
- The plinth level of the building should be kept atleast 1 ½ feet higher than the existing level of out side road with the consideration of economy. The campus drainage system be made effective to avoid stagnation of water.
- Proper location shall be earmarked for residential purpose subject to availability of land. In the master plan provision for Type-II, Type-III and Type IV shall be made. The requirement of quarters subject to specific demand projected by KVS shall be as under :

	Phase-I	Phase-II	Phase-III	Remarks
Type-I	01	01	NIL	Cycle shed/Scooter shed/Garage with servant quarter with main unit shall be provided as per norms for each unit
Type-II	01	01	Actual requirement	
Type-III	04	04	Actual requirement	
Type-IV	04	02	Do-	
Type-V	01	NIL	NIL	
	11	10		

However in the master two more blocks each of Type-II & Type-III for Ph-III shall be incorporated.

The Quarters shall be planned as per approved plinth areas of Ministry of Urban Development (CPWD) / Ministry of Defence (MES).

- Sports facilities to be earmarked in the land available with K.V.
- Primary : Play areas with parks open spaces near primary block for play equipments like: Plain slides, wave slides, swings, see-saw, Horizontal ladders, rings, grand slide, climbing apparatus, Merry-go-round etc. However equipment shall not be provided.
 - Middle and Senior Secondary : Hockey field, athletic track with football field, Cricket pitch, Volley ball court, basket ball court, Badminton court, Gymnastics area etc.

STANDARDS FOR PUBLIC SANITARY CONVENIENCES

SCHOOLS

<u>Fixments</u>	<u>For Boys</u>	<u>For Girls</u>
W.C	1 per 40	1 per 25
Urinals	1 per 20	---
Wash Basins	1 per 40	1 per 40
Drinking Water fountain	--- 1 per 50 or part thereof	

	<u>For Males</u>	<u>For Females</u>
W.C	1 per 25	1 per 15
Urinals	nil upto 6 1 per 7 -- 20 2 per 21 - 45 3 per 46 -- 70 4 per 71 -- 100 For 101 -- 200 add @ rate of 3 % For over 200 add @ rate of 2.5 %	
Wash Basins	-- 1 for 25 or part thereof (M /F)	
Drinking water fountain	-- 1 per every 100 persons with Minimum of one on each floor	

NOTE:-

- A ratio of 60(Boys): 40(Girls) of total planned strength of vidyalaya shall be taken into consideration.
- Separate toilets for staff (Gents & Ladies) shall be provided.
- Toilet for differently abled person (Boys, Girls, Gents, Ladies) with necessary fitting/ Fixtures shall be provided as per standards.

Checklist for approval of preliminary drawings for construction of school building with/or/without staff quarters

Name of KV: _____

Type of school Building
(Tick)

- A-I (Single section-plinth area 2640 sqmt) in normal cases (480 students)
- A (two section - plinth area 4200 sqmt) in normal cases (960 students)
- B (three section - plinth area 5560 sqmt) in normal cases (1440 students)
- C (four section - plinth area 6660 sqmt) in normal cases (1920 students)

Agency: _____

S.N	Description	To be ensured by Architect	Remarks of Architect
1.	No. of rooms conforming to KVS space norms	Conforming to KVS space norms/ Few rooms not conforming to KVS space norms, but are functional (give reasons in remarks col)	
2.	Size of rooms conforming to KVS space norms	Conforming to KVS space norms/ Few rooms not conforming to KVS space norms, but are functional (give reasons in remarks col)	
3.	Plinth area	As per KVS norms /Higher than KVS space norms (give reasons in remarks col)	
4.	Provision of cement concrete black board in class rooms	to be made	
5.	Provision of glass equivalent writing board in other academic related rooms (except class rooms)	to be made	
6.	Provision of built-in cup board with shutters upto lintel level and pin up boards in class rooms	to be made	
7.	Provision of built-in cup board with shutters upto lintel in other rooms.	to be made	
8.	Brief specifications of the project	As per KVS/CPWD & soil	

		report or as per KVS/MES & soil report (details to be furnished)	
9.	Detail of fitting/fixtures	As per CPWD/KVS or MES/KVS (details to be furnished)	
10.	Layout of labs with specifications as per KVS space norms	To be developed as per KVS norms	
11.	Ramp to all floors for differently abled persons and children	To be provided as per yardsticks	
12.	Toilet in ground floor for differently abled children	To be provided as per yardsticks	
13.	Drawings with future expansion of school building to next higher category showing required number of rooms in line plan/additions/modifications in dotted lines	To be developed accordingly	
14.	In layout plan provision is made for (Subject to extent of land transferred to KV) (a) Drinking water kiosks in the campus at suitable locations (b) cycle/scooter shed for 100 nos. (c) Canteen (size as per KVS norms) (d) Watchman cabin (e) Sports facilities – for primary children as per KVS norms and hockey, athletic track (200/300 mts), foot ball, badminton, gyms area for h/s students.	To be made To be made To be made To be made/partly/made as land is not adequate	
15	Provision of 24 nos (minimum) (for A-I, 'A' 'B') and 30nos. (minimum) (for 'C' type) power points and one extra point for teacher, in each computer room.	To be made	
16	Whether filling required	If yes, please show the location with dimensions in Drawings mentioning existing GL, Formation level and depth of filling.	
17	Provision of rain water harvesting, fire fighting and other mandatory requirements/ provisions	To be made. Necessary approvals from concerned authorities to be taken before taking up the work and after completion	
18	Layout/Preliminary drawings	Drawing to be developed as	

	developed as per local bye-laws and national building code/AAI CRZ/ASI/NDMA regulations etc.	per mandatory bye-laws. Necessary approvals to be taken from concerned authorities before taking up the work and after completion	
19	Toilets for boys/girls/staff adequately provided at suitable locations in the building as per standards (Boys 60% girls 40% ratio of total no. of students)	Drawing to be developed with adequate numbers as per standards	
20	Segregation of wet areas/toilet blocks from walls of main building to prevent seepage.	To be planned accordingly/not possible (given reasons)	
21	Attached toilet to principal room and medical room provided	Drawings to be developed accordingly	
22	Cooler spaces (inside building at suitable locations provided	Drawings to be developed accordingly	
23	Plinth area of staff quarters as per CPWD/MES yardsticks	Plinth area to be per yardsticks of CPWD/MES	
24	Exclusive location of staff quarters including future requirement, open area for get together/ functions etc. with low height wall separating school area.	To be incorporated	
25	Provision of cycle shed/ scooter shed/garage for various types of staff quarters	To be made	
26	Any other required provisions made as per architectural considerations	To be indicated, if any and incorporated	
27	Any other provision made as per by-laws and mandatory requirements	To be indicated if any and incorporated	
28	Provision of assembly Hard standing for 480/960/1440/1920 students made with covered stage	To be made at suitable location	
29	Provision Internal Switch Boards/ M.C.B. etc. at lintel level only.	To be ensured	
30	Width of corridors in school building	Min.1800 mm for singly loaded. Min.2100 mm for doubly loaded.	
31	Explore possibility of singly loaded corridors.	Possibility to be explored. School building fully singly loaded corridor/partly singly loaded corridors.	

32	Proposed plinth level of buildings	Higher than G.L of existing outside road / H.F.L of the place/ at par with Recently Constructed Government Buildings in the vicinity (TO be justified) However minimum plinth height 450 mm from formation level.	
33	Requirement of retaining wall/ protective measures	Not required / incorporated in drawings.	
34	Provision of exhaust Fans. wherever necessary and security lights on building corners made.	Provision to be made in detailed drawings.	
35.	Provision of separated toilets for staff gents/ ladies including one each toilet for differently abled persons	To be made	
36.	Clear demarcation of plot boundaries shown in the layout plan as per survey plan after physical verification in presence of principal and sponsors and also incorporating existing features (i.e. structures, elec. Lines. Trees etc. (if any) including contours. According to verified physical boundaries, proposed boundary wall shall be incorporated.	layout plan/to be developed accordingly	

Note :-

(*) – Local by laws and National Codes are final and are to followed wherever contradictions observed above.

Signature of Architect-

Signature of Competent
Technical Authority of const. agency

09/12 SB

CERTIFICATE – I

(This certificate is invariably be obtained from construction agency and submitted alongwith preliminary estimate)

Sub: Estimate for construction of _____
at KV _____

This is to certify that estimate amounting to Rs. _____ submitted by our office for the above cited work is a consolidated estimate covering the following provisions apart from construction of buildings as per scope including internal services :-

- (i) Development of site i.e. internal roads/paths/retaining wall (if required), external water supply viz sump, tanks on building, pumps(submersible/booster), area drainage, external sewer arrangement viz. septic tank, soak pits etc.
- (ii) Bulk services (civil & elec.)
- (iii) Electric service connection including charges payable to local Elec. Board, if any.
- (iv) Drinking water including connection and charges payable to local authorities (if any) and tube-well (if required)
- (v) All provisions are made after ascertaining demand
- (vi) Other provisions as per norms and site conditions,(if any)

It is further certified that ^{on} demolition of existing structures, removal of electric lines, trees etc. is required.

Being 'Deposit Work' necessary co-ordination is being made by this department with local authorities and ensure approval of drawings before and after execution of work. However, Principal, KV will extend his help in this regard.

It is further certified that on completion, these structures can be put in use with commissioning of all services viz. Drinking water, electricity, sewage disposal etc. without any difficulty.

Signature of competent Technical Authority
of Construction Agency

09/12 SB

CERTIFICATE – II

(This certificate is invariably be furnished by Principal alongwith estimate)

Sub : Estimate amounting to Rs. _____ framed by _____ (Name of construction agency) for construction of _____ at KV, _____

This is to certify that the above construction work has been planned on the overall land measuring _____ acres already transferred to this KV on lease / permanent grant basis . Further the piece of land is clear and free from obstructions, encroachments, trees, elec. Lines, litigations, court cases. No demolition of structures is involved.

The proposal and construction agency have been approved in VMC meeting held on _____. The location of proposed construction work has been decided by a team of officials of VMC (Chairman or his authorized representative), Construction agency, and the undersigned.

Signature of Principal

09/12 SB

CERTIFICATE -III
(To be obtained from competent authority of Sponsors)

GRANT OF APPROVAL FOR CONSTRUCTION

Principal , Kendriya Vidyalaya _____approached this office for grant of approval/ permission to undertake construction of _____ on the basis of drawings developed and estimate framed by _____ on the land measuring _____ acres allotted on lease / permanent grant to this KV by _____. As per allotment conditions prior permission / approval is to be obtained from Competent authority .

The undersigned has no objection in taking up this work on the aforesaid land and approval / permission is hereby granted in this regard.

SIGNATURE OF COMPETENT AUTHORITY
WITH DATE & SEAL

Note: For Defence sector KVs - DEO (Compulsory) and also Chairman , VMC (or any other authorized Officer)

For Railway Sector KVs - DRM and/or, GM (to be confirmed from sponsors) ,and also Chairman , VMC (or any other authorized officer)

For State Govt. Sector - DM/ Collector (or any other authorized officer)

For KVs not covered above - may be confirmed from Sponsors.

09/12 SB

DRAWING NO. KVS-01

CLASS ROOM (PRIMARY/HIGHER SECONDARY)

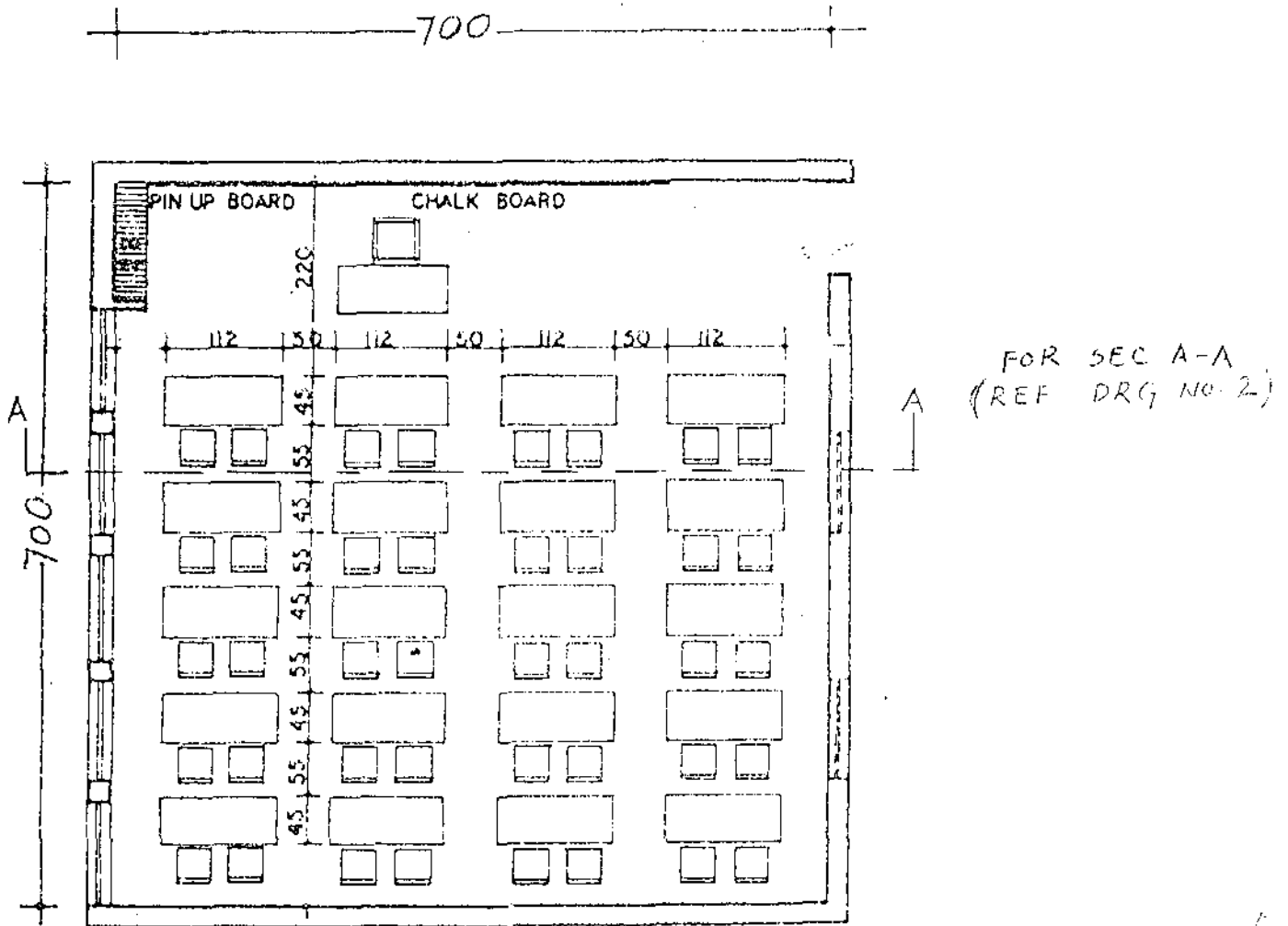

FOR SEC A-A
(REF DRG NO. 2)

NOT TO SCALE
DIMENSIONS IN CMS

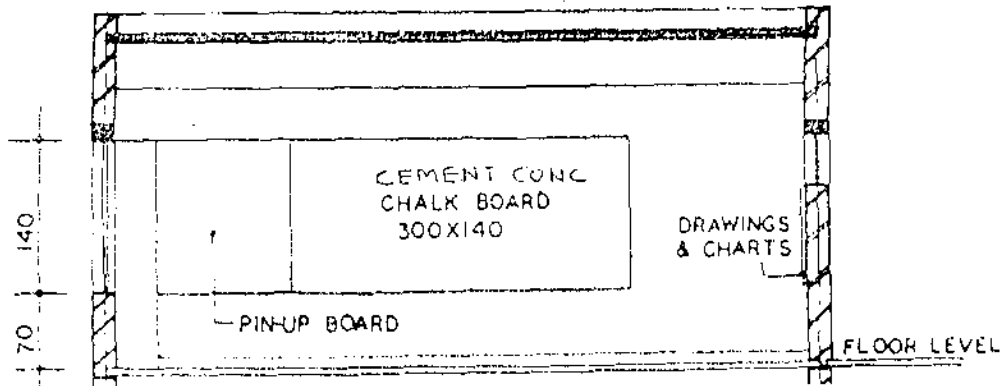

SEC - A.A

BLACK BOARDS FOR SCHOOLS

(Ref : Indian Practical Civil Engineers' Hand Book - 2001)

Height from floor to base of the black board

Primary Class Rooms	----	53 cms
Elementary Class rooms	----	64 cms
High School Class Rooms	----	76 cms

Height of Black Boards ---- 1.06 mts , 1.22 mts, 1.37 mts,
(1.22 mts is the best)

Specifications ---- Under coat of 12 mm cement plaster of 1 Cement , 2 Sand and 1 Charcoal powder. Finishing coat of 1 Cement and 1 Charcoal 3 mm thick.

Paint ----- Dissolve $\frac{1}{2}$ kg of shellac in 5 litres of methylated spirit and add $\frac{1}{2}$ kg of ivory black , 75 gms of finest flour emery and $\frac{1}{4}$ kg of ultramarine blue. Mix and put in stoppered bottles. Shake well when using.

PHYSICS LABORATORY

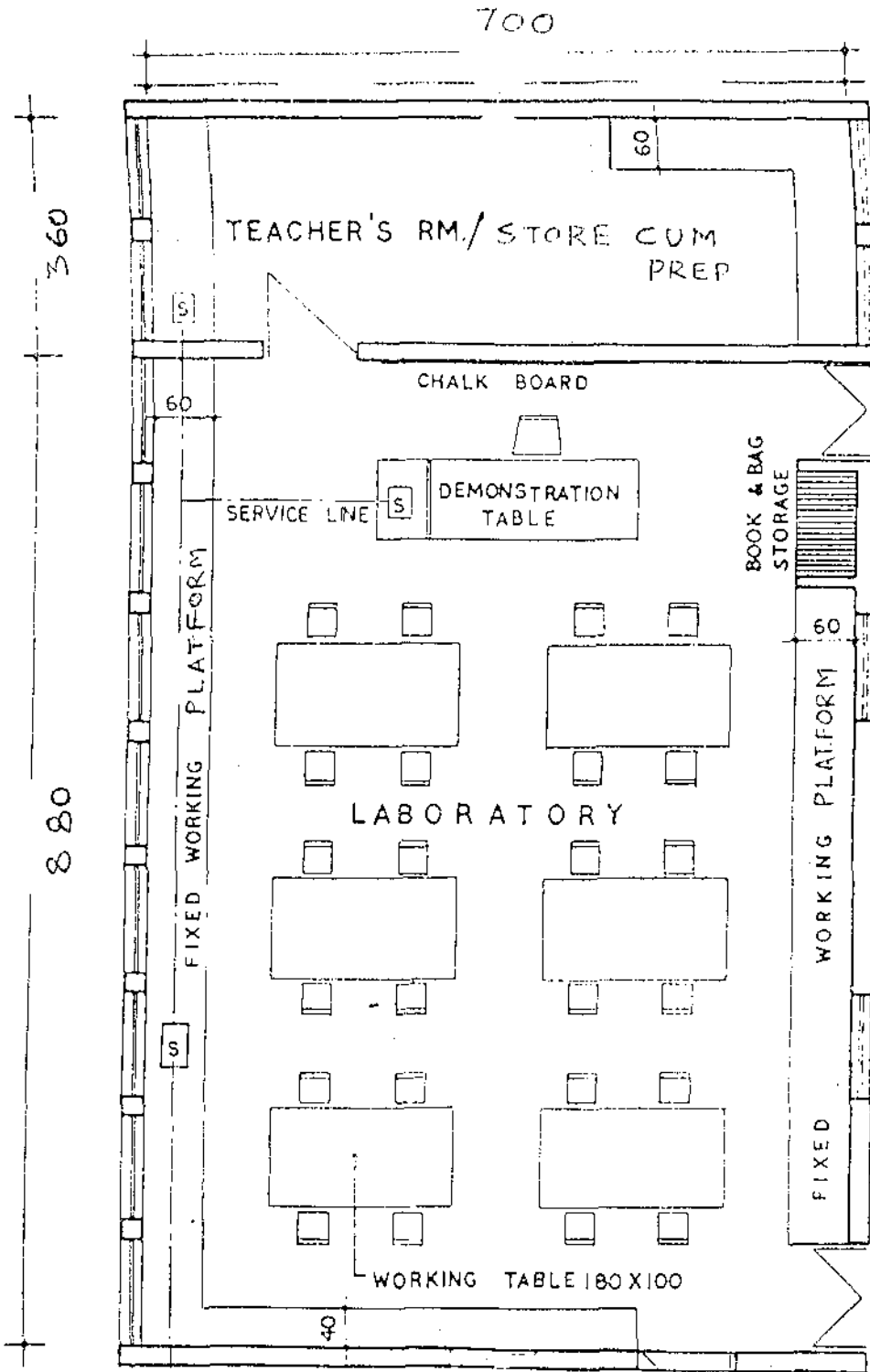

S-SINK

- WORKING PLATFORM HEIGHT 83 CMS & SI BE CONSTRUCTED BY CONSA
- WORKING TABLES (WOODEN) SHALL BE PROCURED BY PRINCIPAL

NOT TO SCALE
DIMENSIONS IN CMS

CHEMISTRY LABORATORY

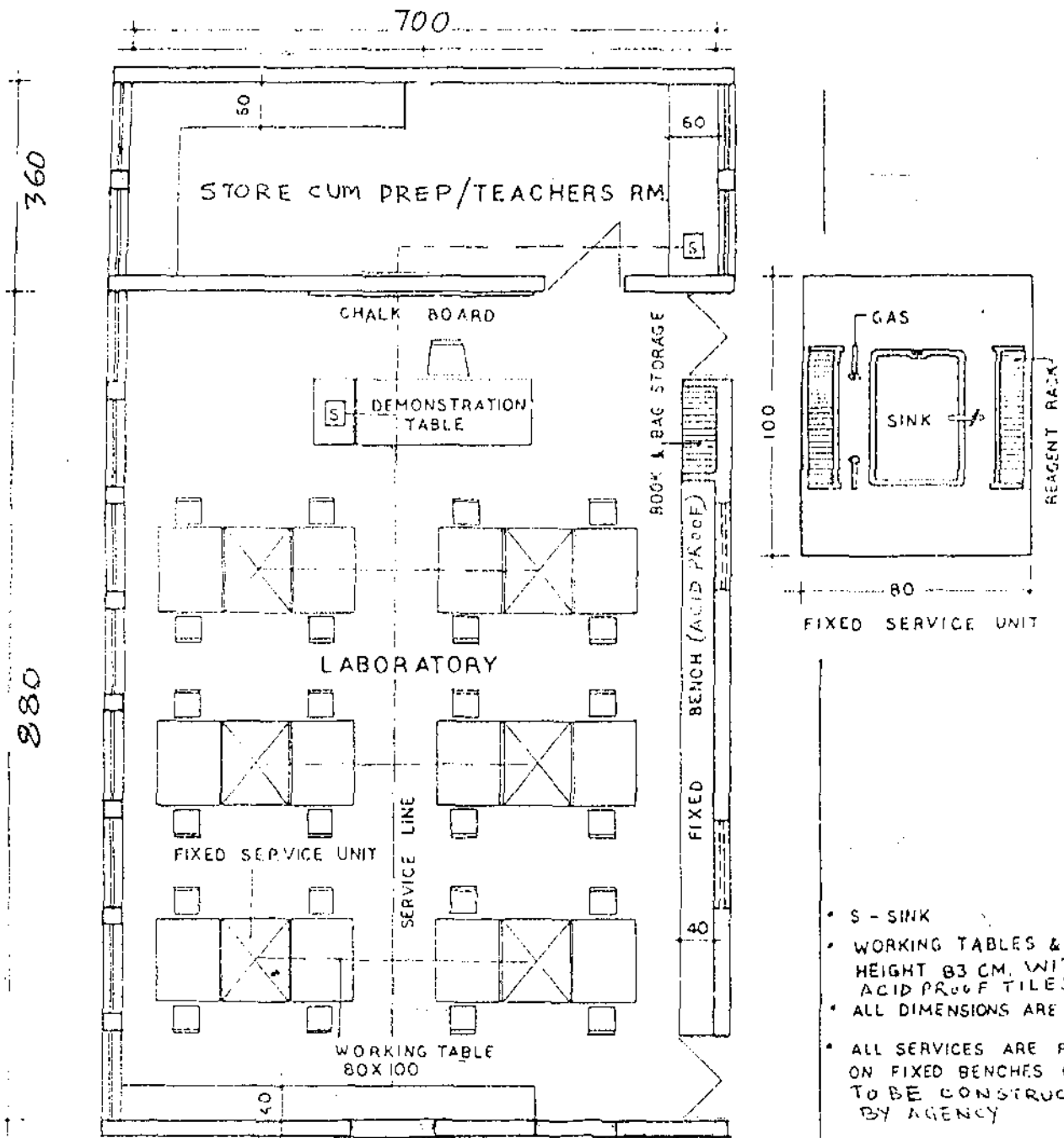

- S - SINK
- WORKING TABLES & BENCHES HEIGHT 83 CM. WITH ACID PROOF TILES
- ALL DIMENSIONS ARE IN CM.
- ALL SERVICES ARE PROVIDED ON FIXED BENCHES ONLY. TO BE CONSTRUCTED BY AGENCY

DRAWING NO. KV505

BIOLOGY LABORATORY

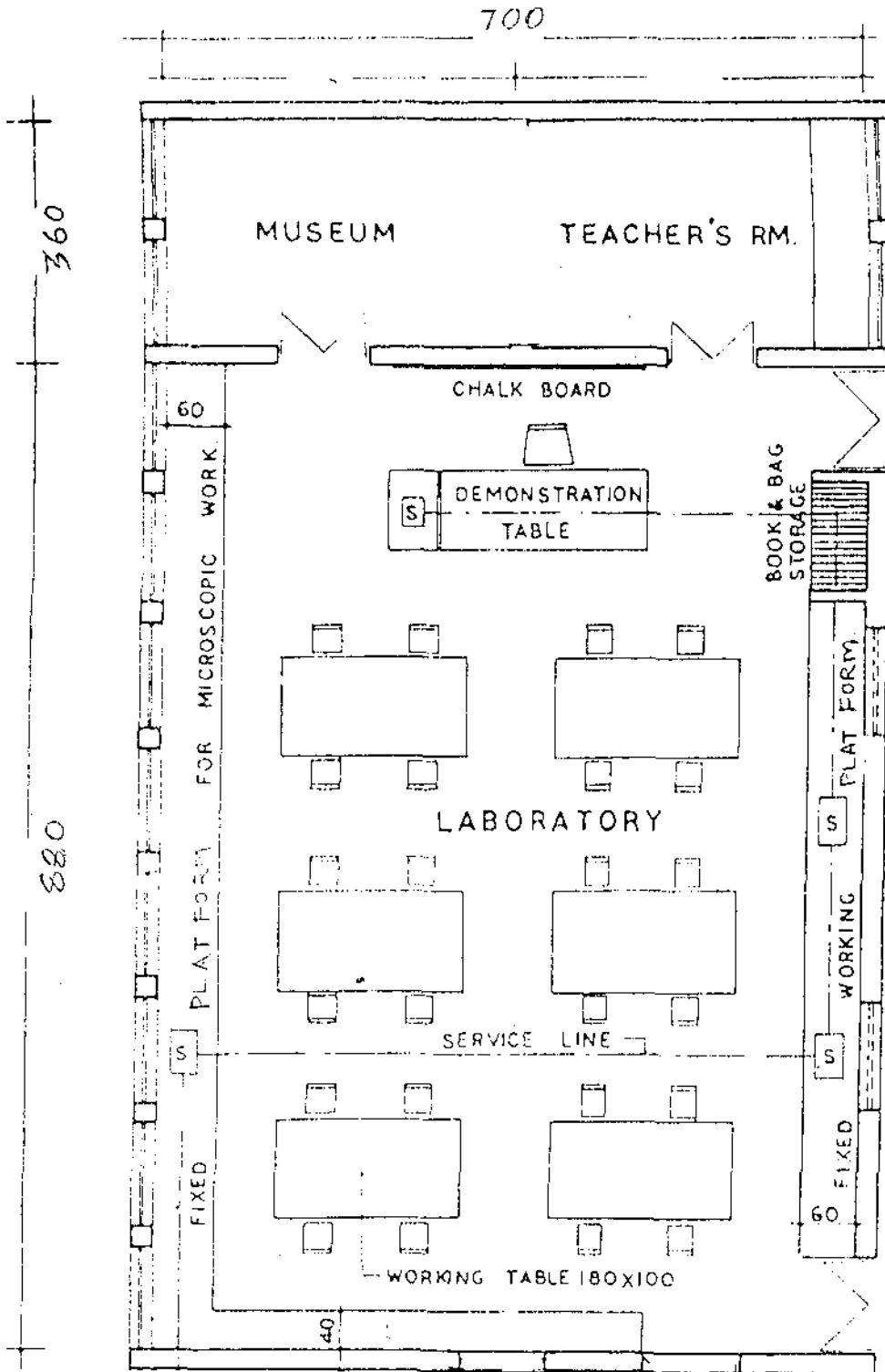

ALL DIMENSIONS ARE IN CM.

S-SINK
WORKING PLAT FORM
HEIGHT 83 CM. &
SHALL BE CONSTRUCTED
BY AGENCY

WORKING TABLES
(WOODEN) SHALL BE
PROCURED BY
PRINCIPAL

DRAWING NO. KVS-06
ART AND CRAFT ROOM
(SUGGESTIVE ARRANGEMENT
OF FURNITURE)

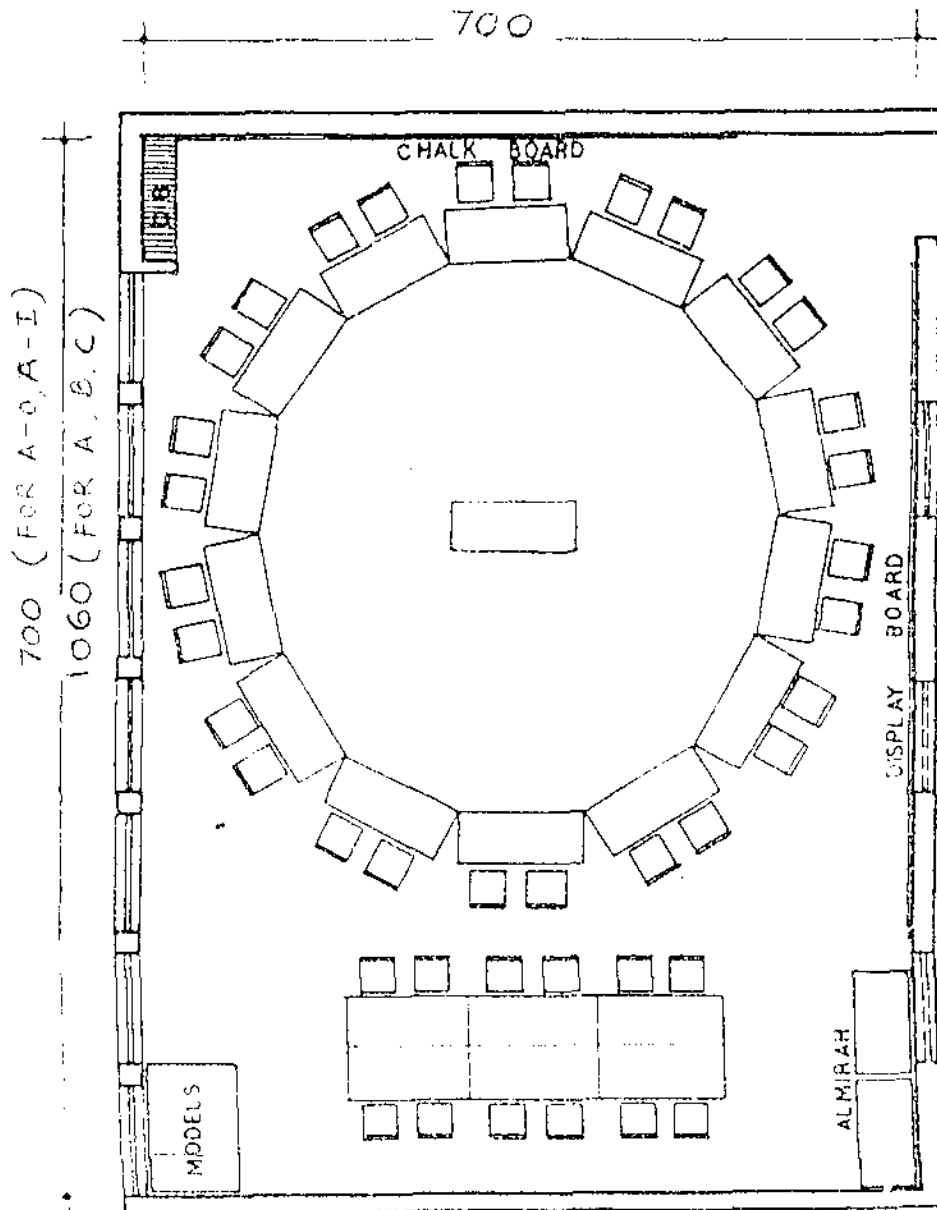

TABLES / FURNITURE
TO BE PROVIDED BY
PPE/K.V.

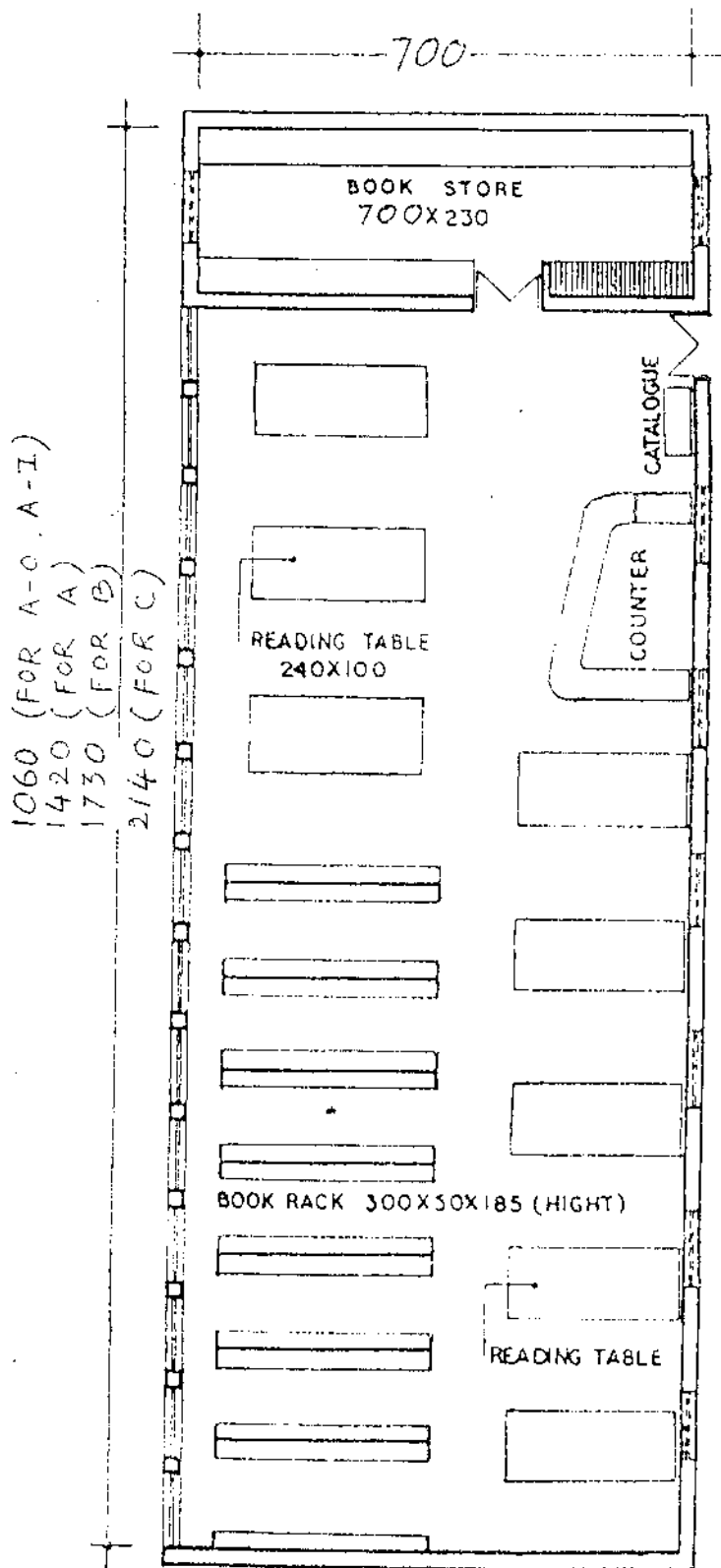

DIMENSIONS IN CMS
NOT TO SCALE

DRAWING NO. KVS-08
PRINCIPAL'S ROOM

ATTACHED TOILET
SHALL BE SUITABLY
LOCATED

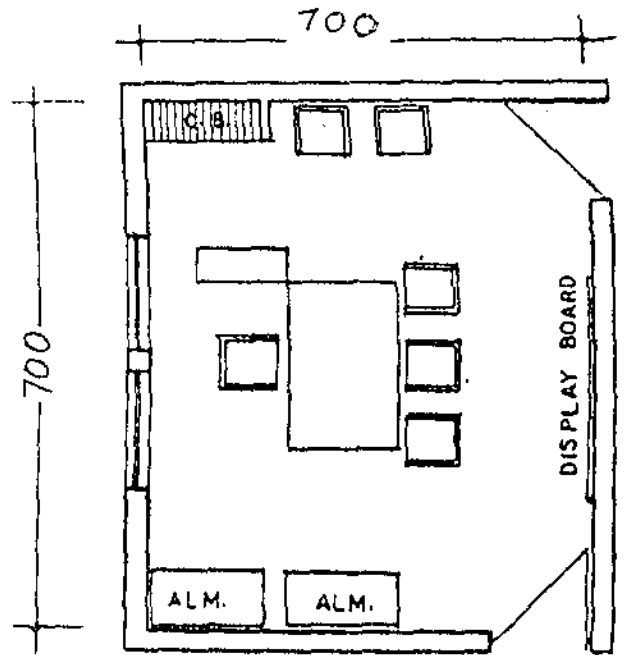

DRAWING NO.
MEDICAL UNIT

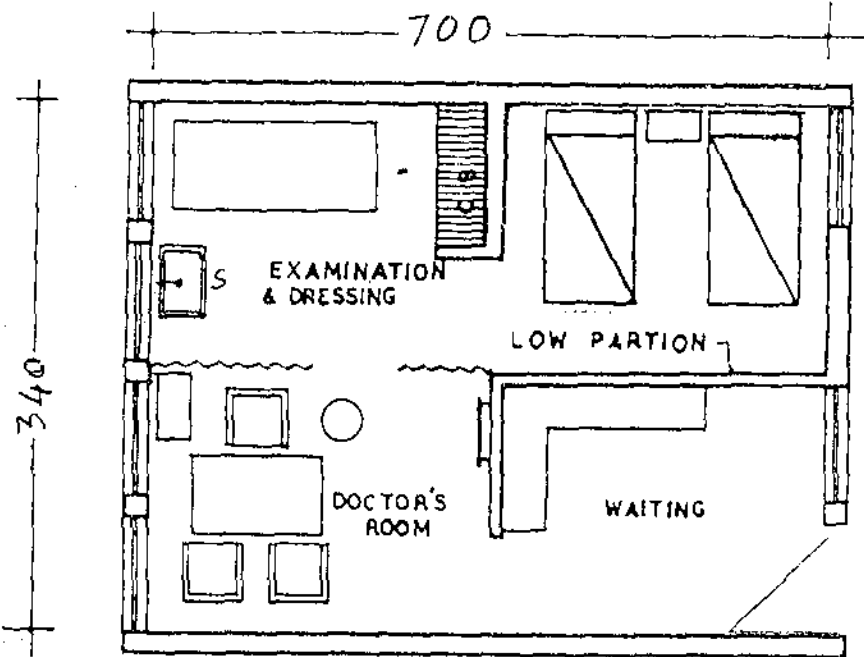

S - SINK

DRAWING NO. KVS-09
OFFICE FOR SCHOOLS

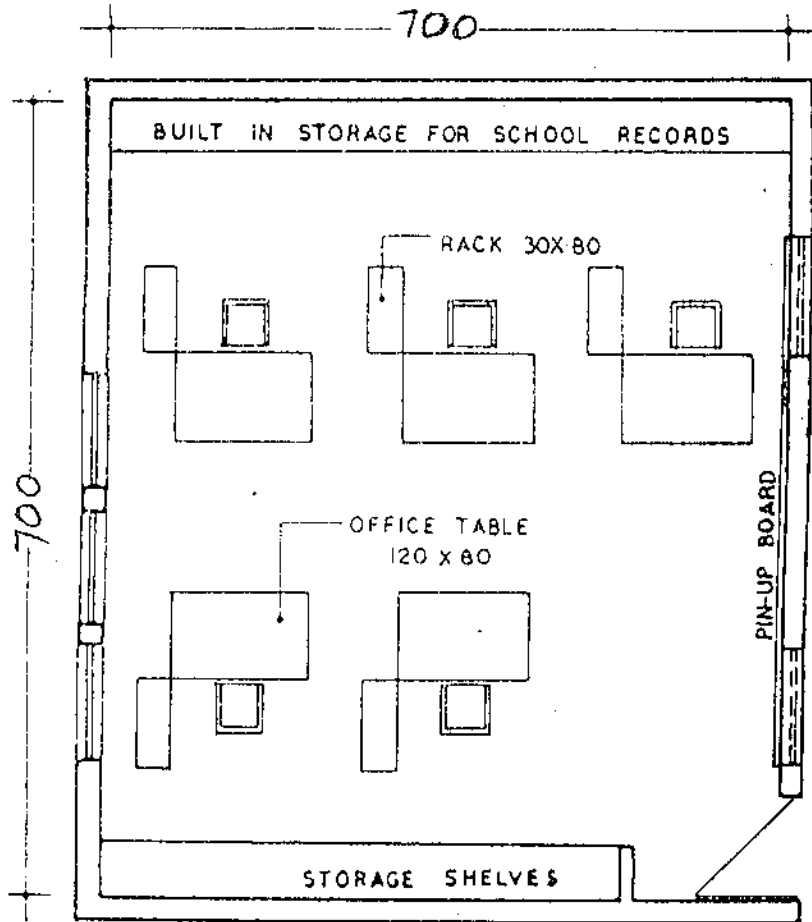

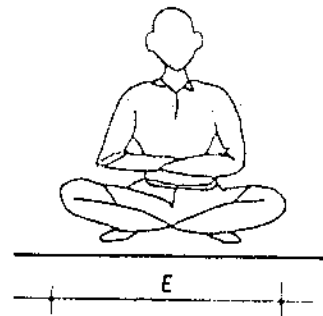
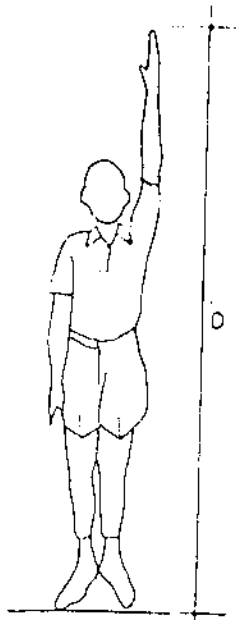
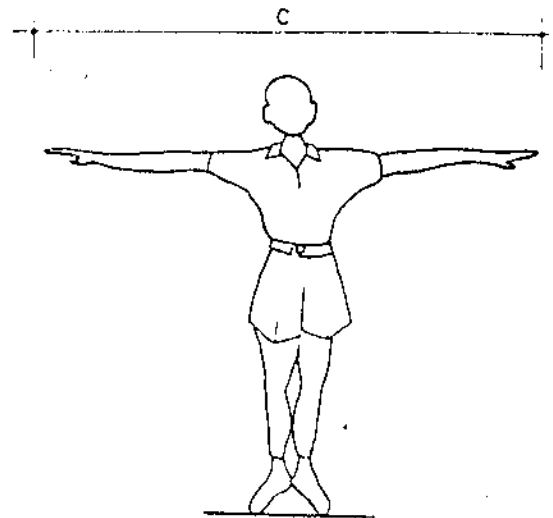
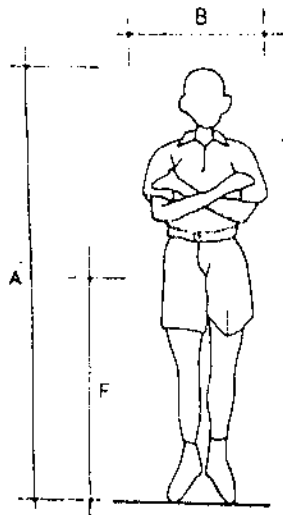

ANTHROPOMETRIC DIMENSIONS (In MM)

AGE	A	B	C	D	E
5	1060	318	1060	1272	424
6	1130	334	1130	1356	452
7	1180	354	1180	1416	472
8	1220	366	1220	1464	488
9	1280	384	1280	1536	512
10	1370	411	1370	1644	548
11	1400	420	1400	1680	560
12	1420	426	1420	1704	568
13	1470	441	1470	1724	588
14	1530	459	1530	1836	612
15	1590	477	1590	1908	636
16	1630	489	1630	1956	652

DRAWING NO. KMS-11

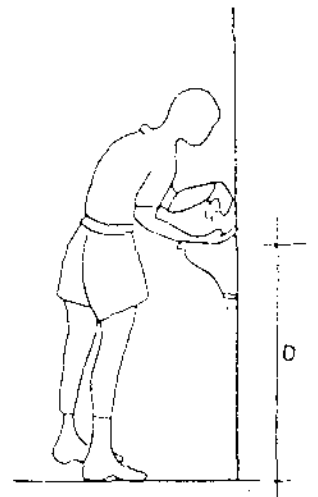
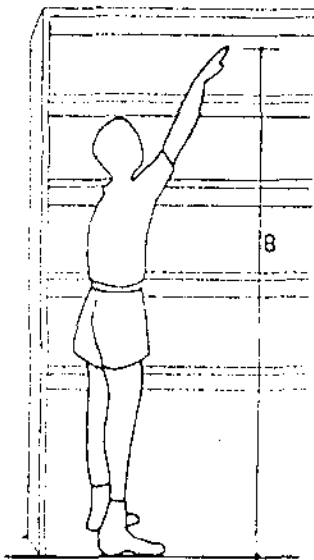
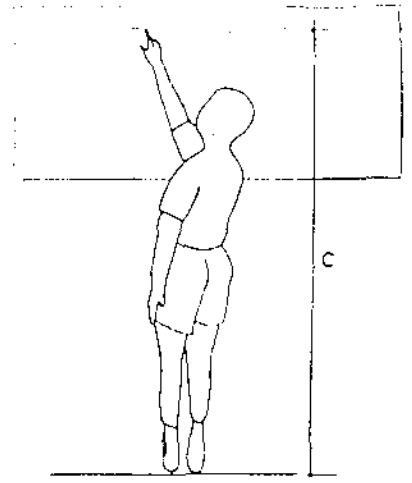
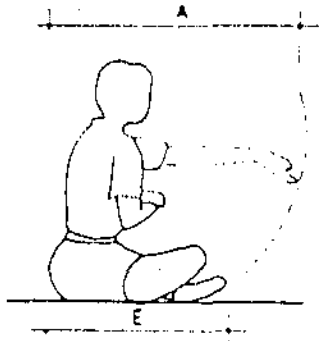

REACH DIMENSIONS (In MM.)

AGE	A	B	C	D	E
5	636	1166	1166	530	329
6	678	1243	1243	565	350
7	708	1298	1298	590	369
8	732	1342	1342	610	378
9	768	1408	1408	640	397
10	822	1507	1507	675	417
11	840	1540	1540	700	434
12	852	1562	1562	710	448
13	882	1617	1617	735	459
14	918	1683	1683	765	474
15	954	1749	1749	795	493
16	978	1793	1793	815	505

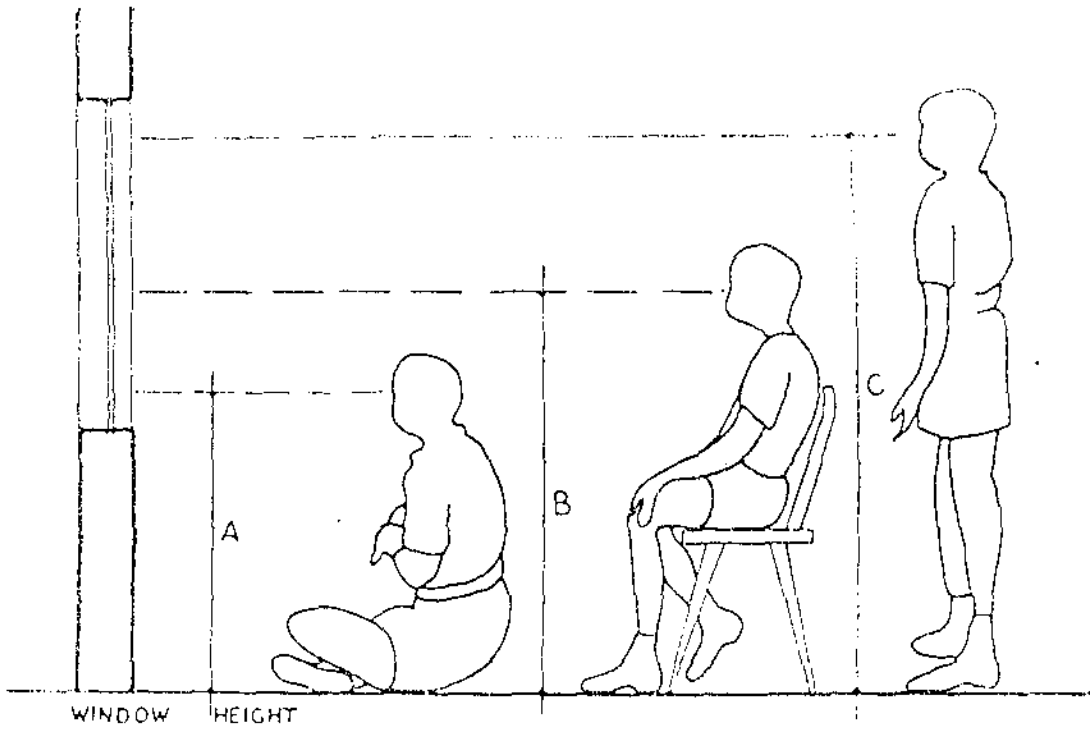

EYE LEVEL DIMENSIONS (In MM.)

AGE	A	B	C
5	445	731	986
6	475	779	1051
7	496	814	1097
8	513	842	1135
9	538	883	1190
10	578	945	1273
11	588	966	1302
12	596	980	1321
13	617	1014	1369
14	643	1056	1423
15	668	1097	1479
16	685	1125	1516

DRAWING NO. KVS-13

STORAGE AND REACH

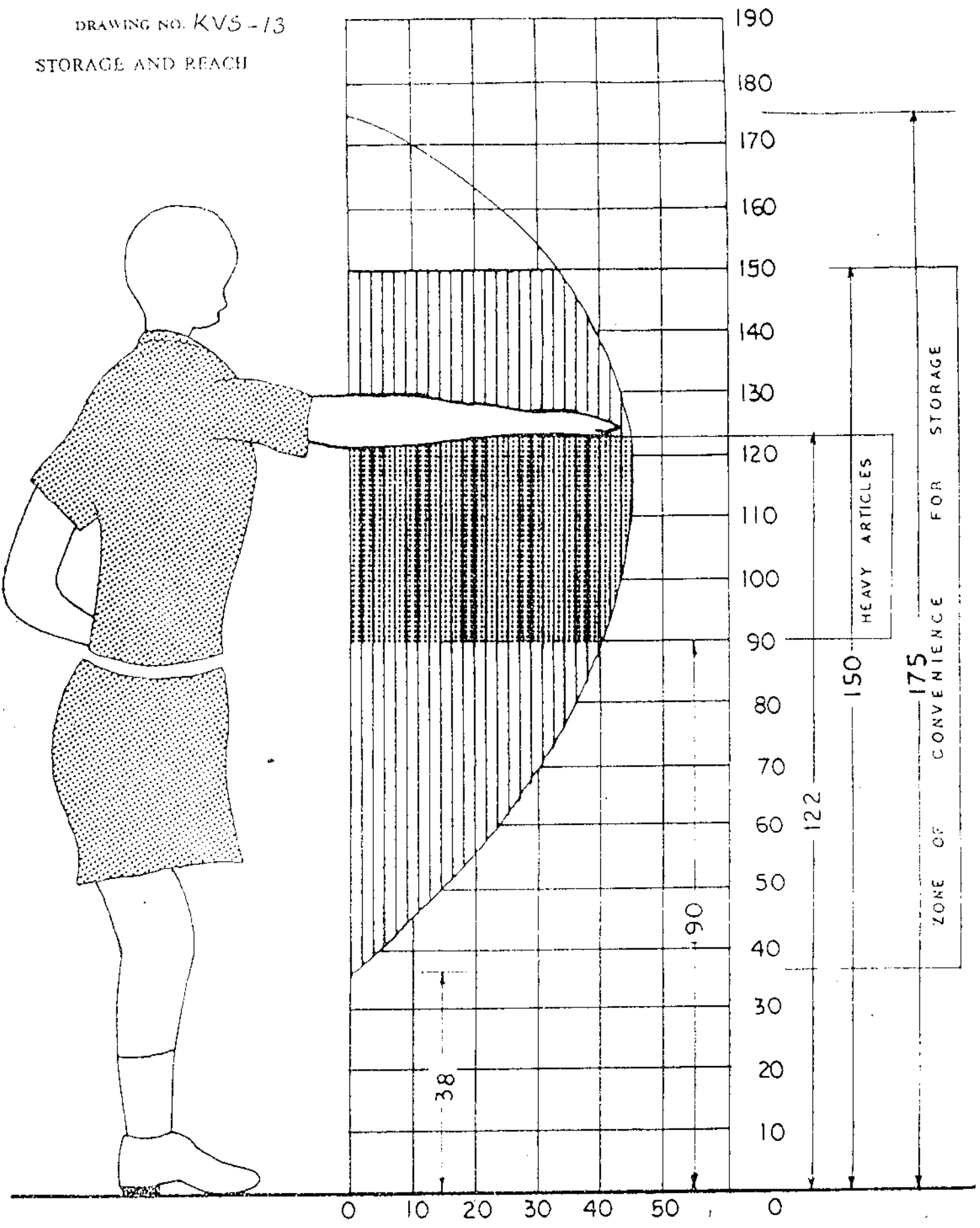

DRAWING NO KVS - 14
 INTER-RELATIONSHIP OF SPACES

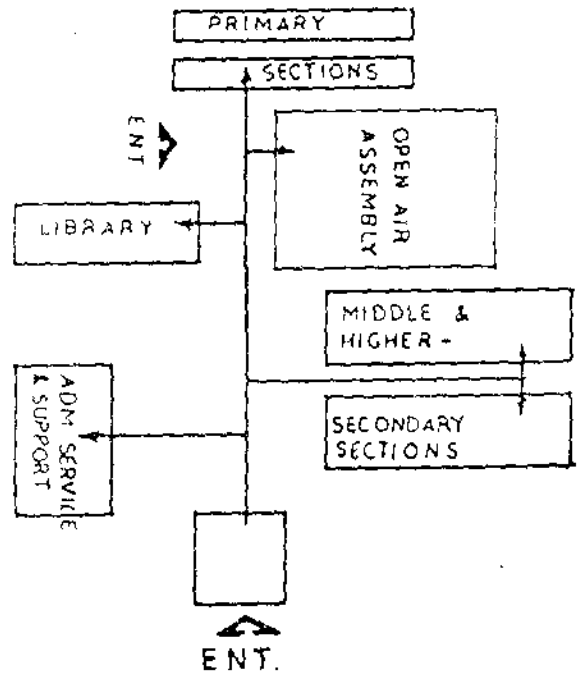
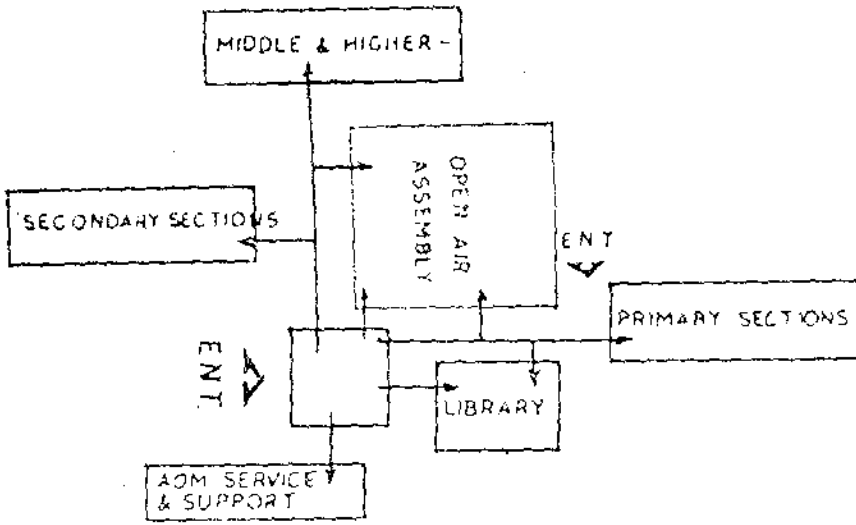

SCHEDULE FOR OPENING

S. NO.	TYPE	SIZE	LINTEL
1	D	900 X 2100	2100
2	R.S.	1150 X 1200	2100

NOTE :-

- D - DOOR
- R.S. - ROLLING SHUTTER

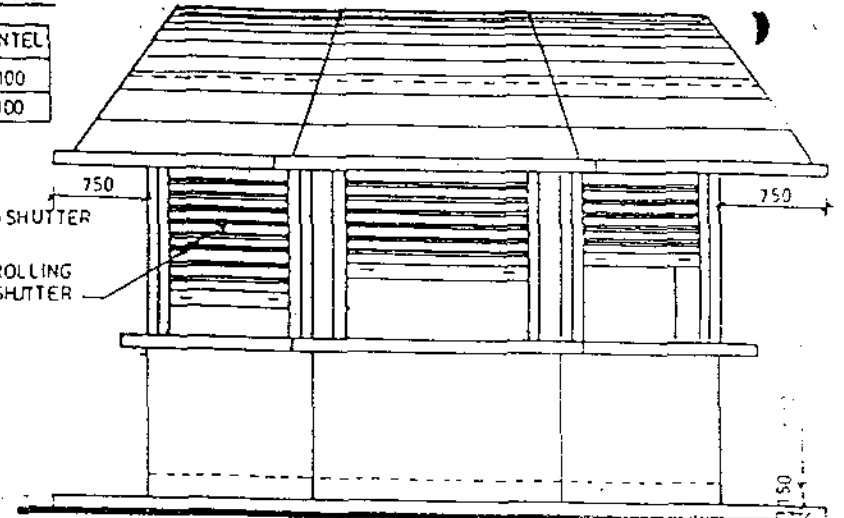

ELEVATION

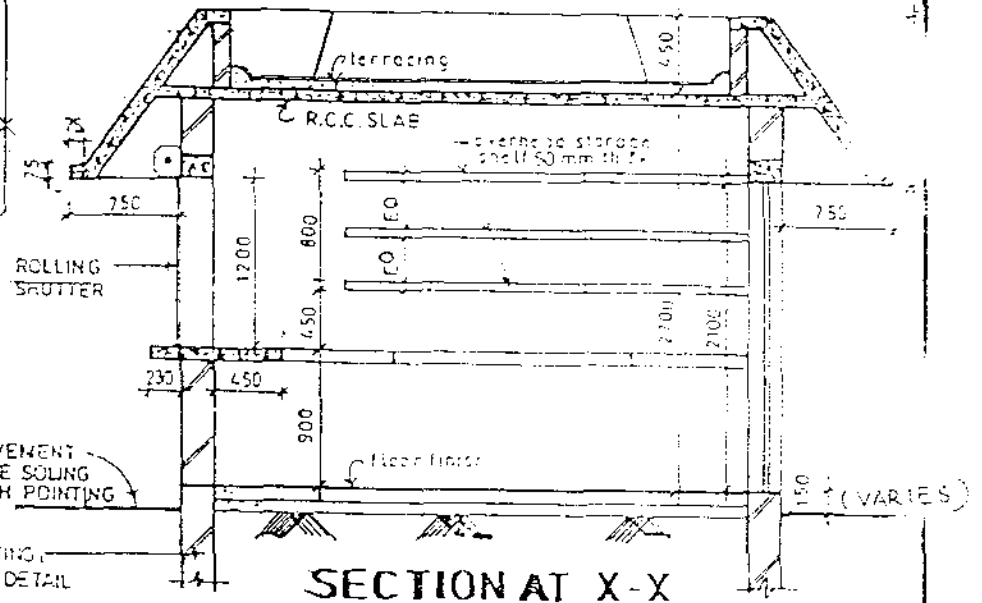

SECTION AT X-X

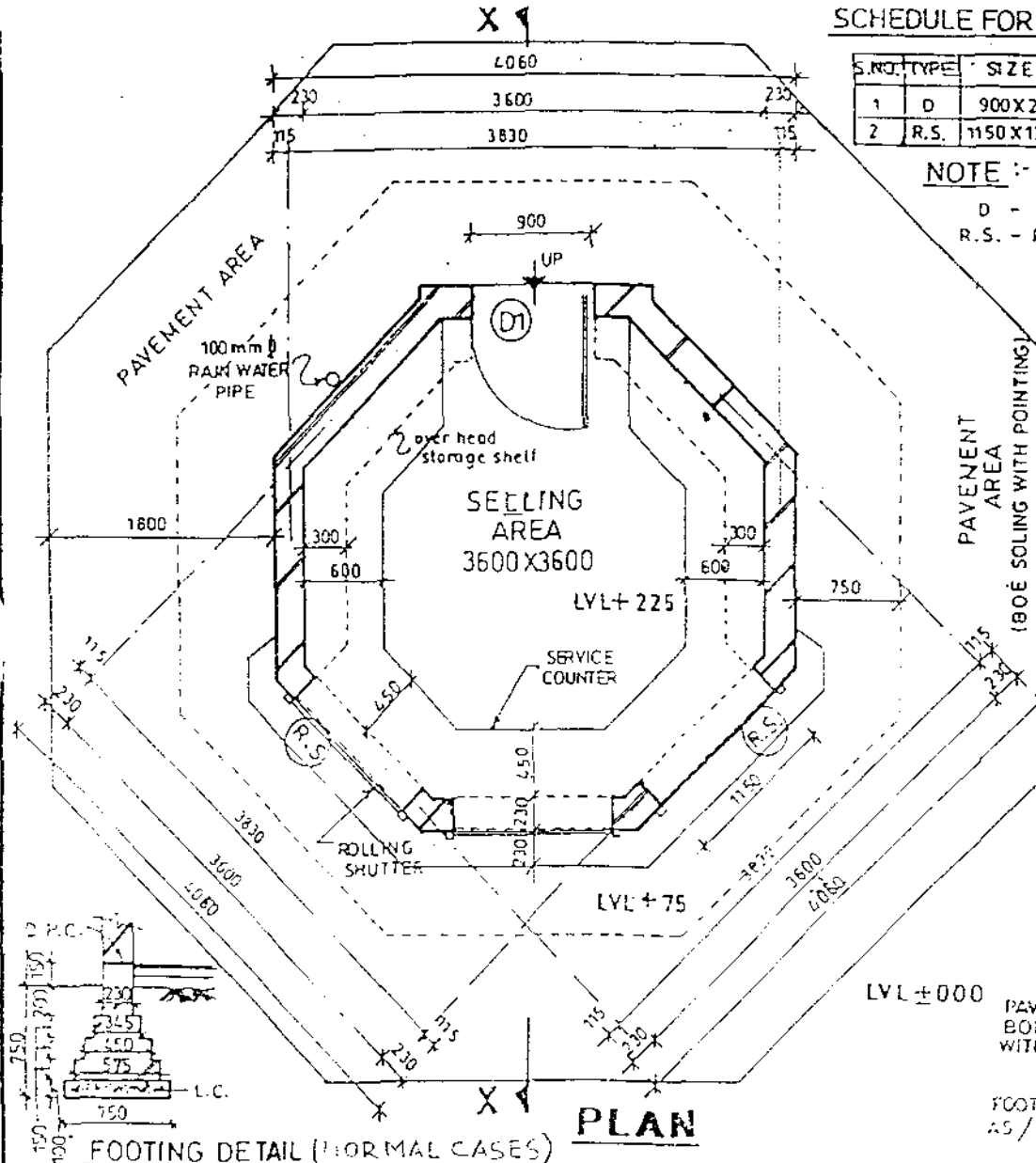

PLAN

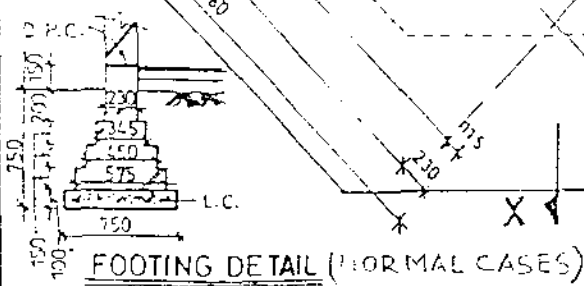

FOOTING DETAIL (NORMAL CASES)

**PROPOSED CANTEEN
FOR (STANDARD SIZE)
KENDRIYA VIDYALAYA**

DRG NO. :-	SHEET NO. :- KVS-16
SCALE :- 1 : 50	DATE :-

34

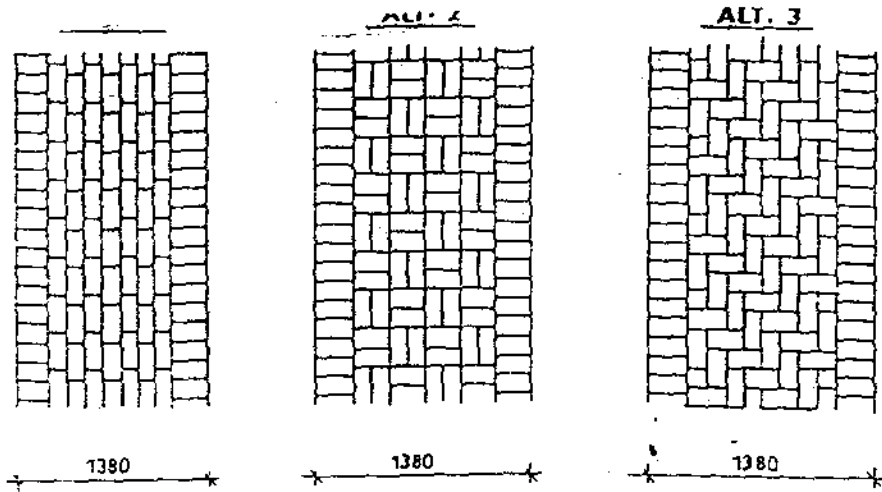

DESIGN OF BRICK PAVING

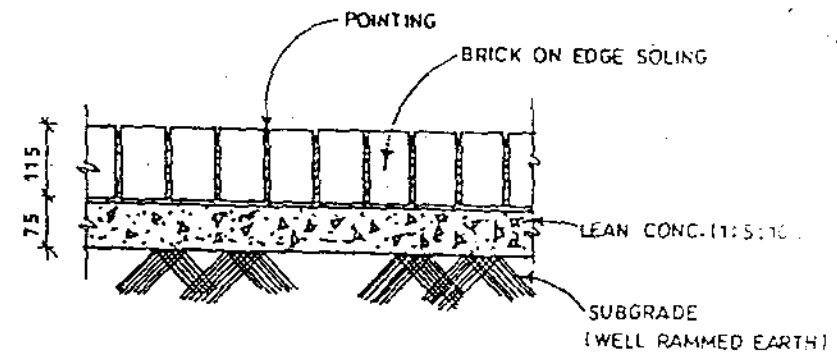

SEC. DETAIL
(HARD STANDING FOR PRAYER GROUND)

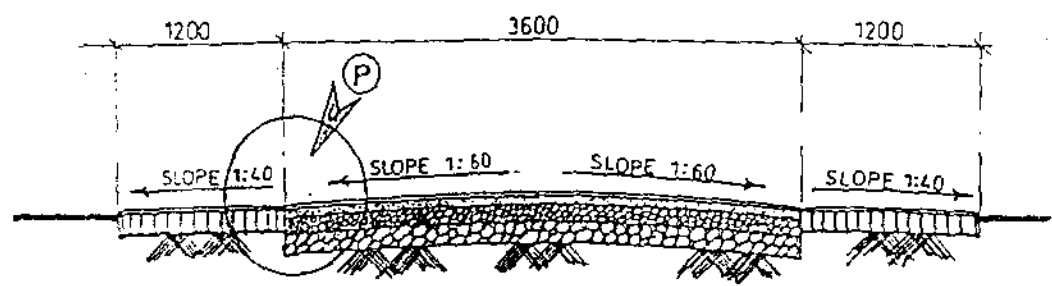

CROSS SECTION (PATHWAY & ROAD)

ROAD FOR LIGHT TRAFFIC ONLY

NOTE: C.C. ROAD ALSO SUGGESTED WHERE RAINFALL IS MORE

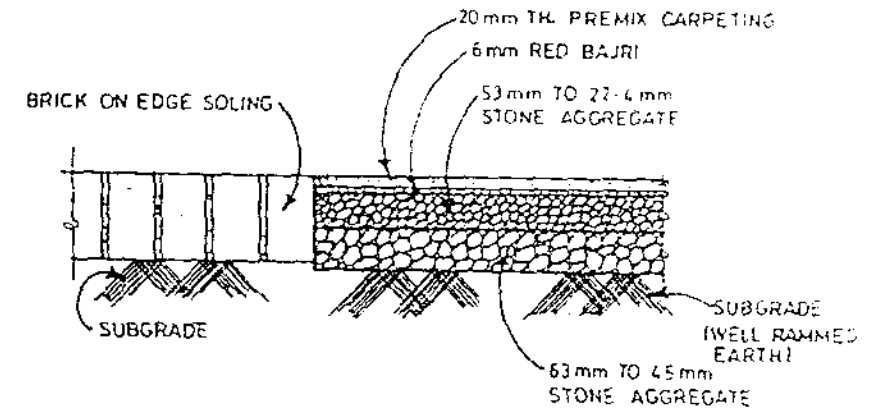

DETAIL AT 'P'

PATHWAY, ROAD & HARD STANDING
SUGGESTIVE PLANS, FOR
KENDRIYA VIDYALAYA SANGTHAN

SCALE :-	DRG. NO.
	KVS-18
SHEET NO. :-	DATE :-

36

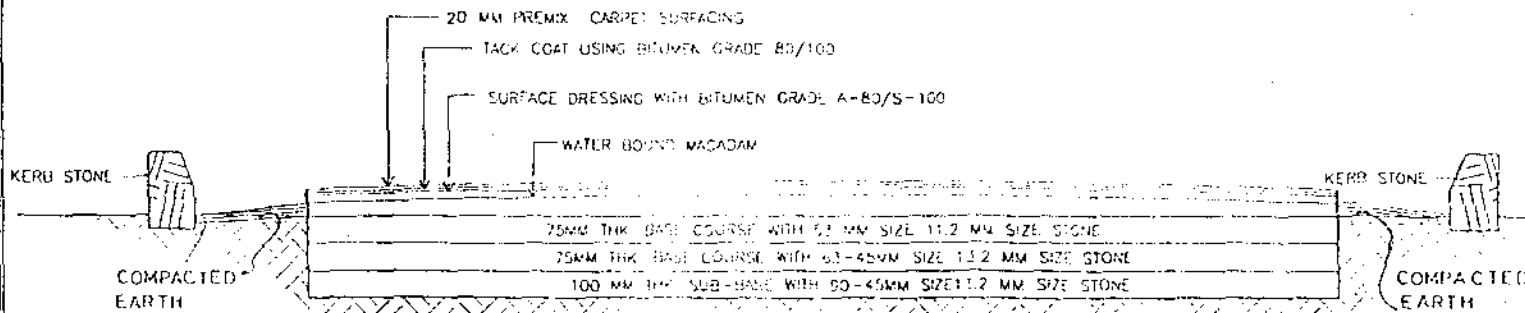
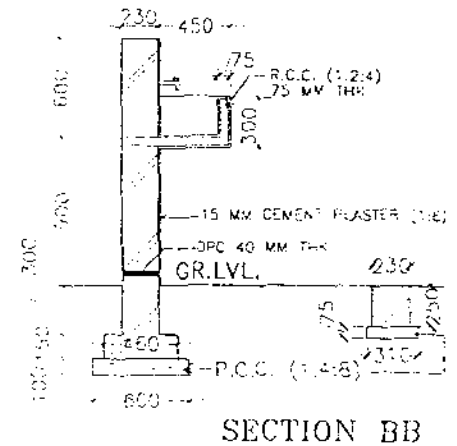
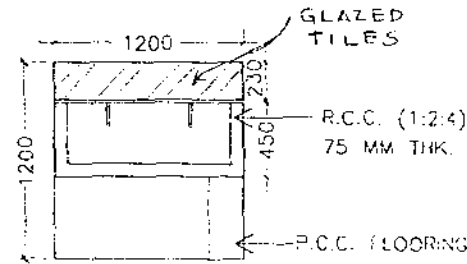
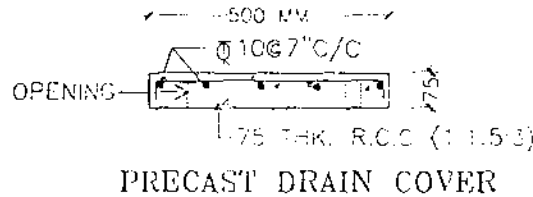
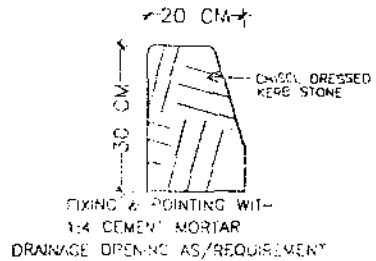
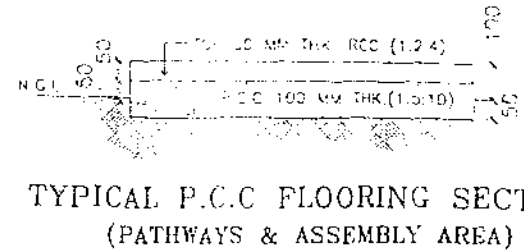
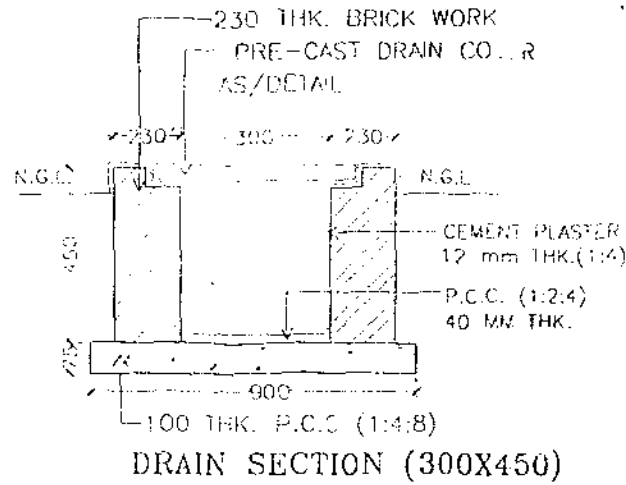
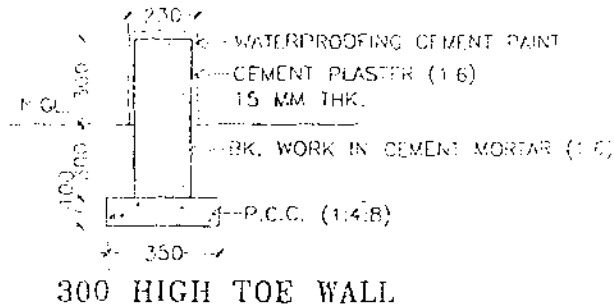

NOTE: C.C. ROAD ALSO SUGGESTED WHERE RAINFALL IS MORE

SUGGESTIVE PLANS	
EXTERNAL SITE DEVELOPMENT DETAILS	
SCALE - 1:50	DATE -
DESIGNED BY -	ORG. NO. KVS-20

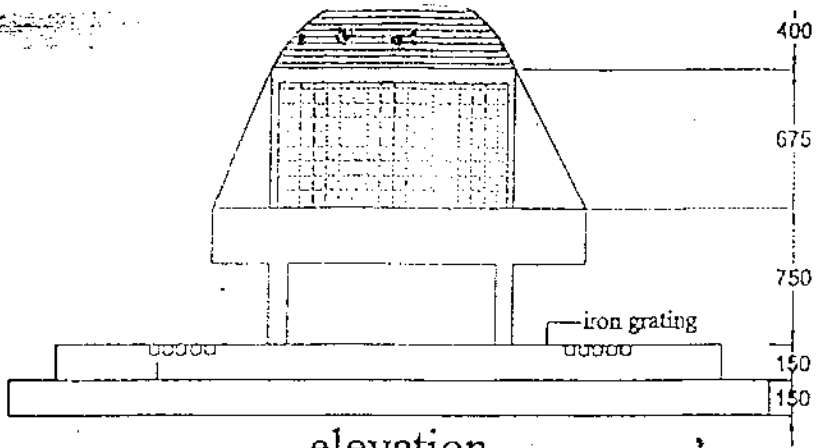

elevation

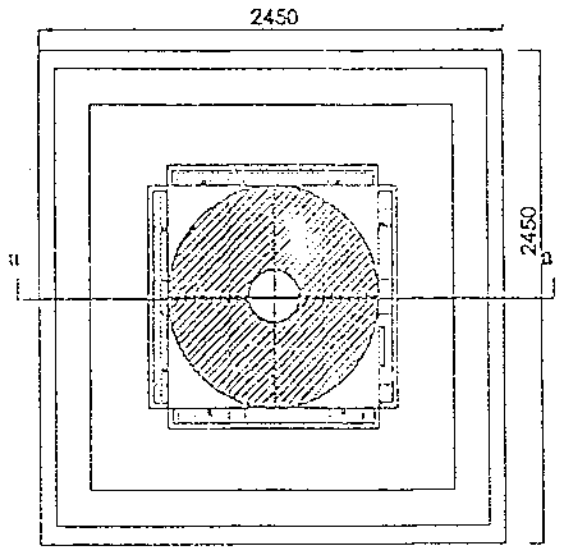

plan

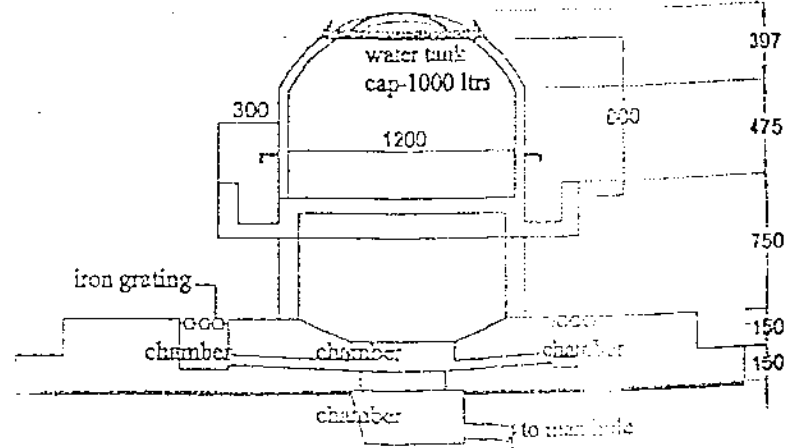

section a-a

detail of water kiosk
 (OUTSIDE BUILDING)
 (SUGGESTIVE PLAN)

DRG NO- KVS-21

39

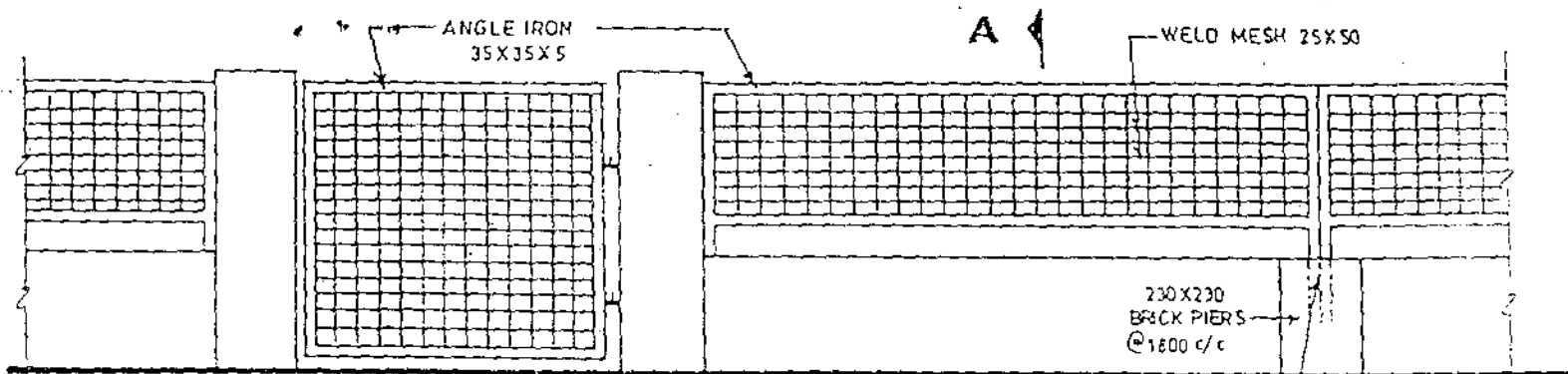

ELEVATION ALT-1

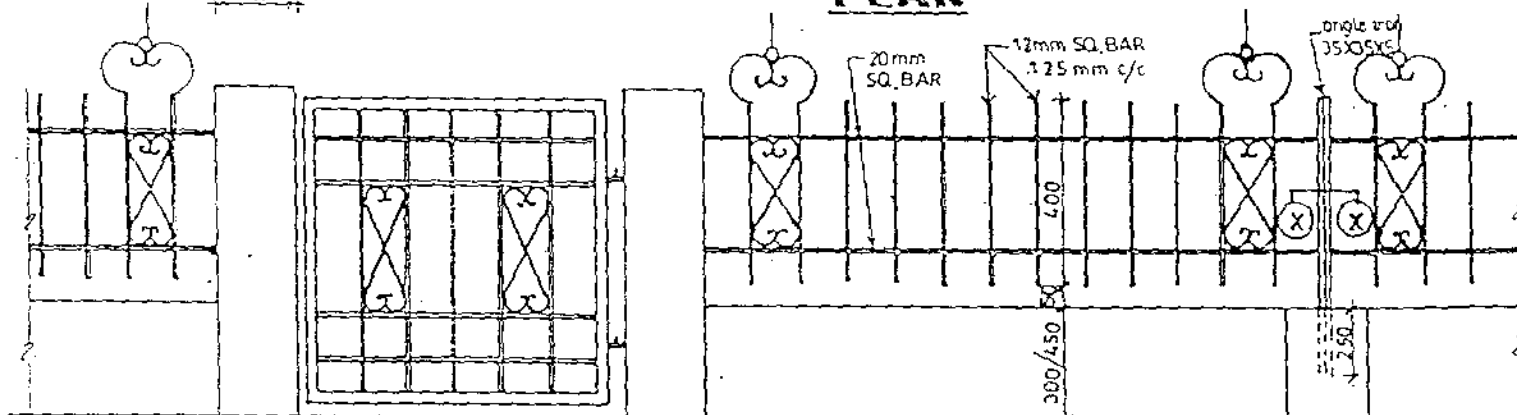
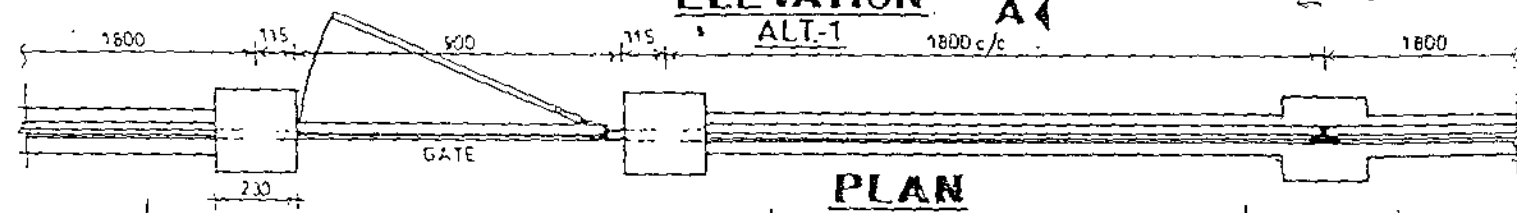

ELEVATION ALT-2

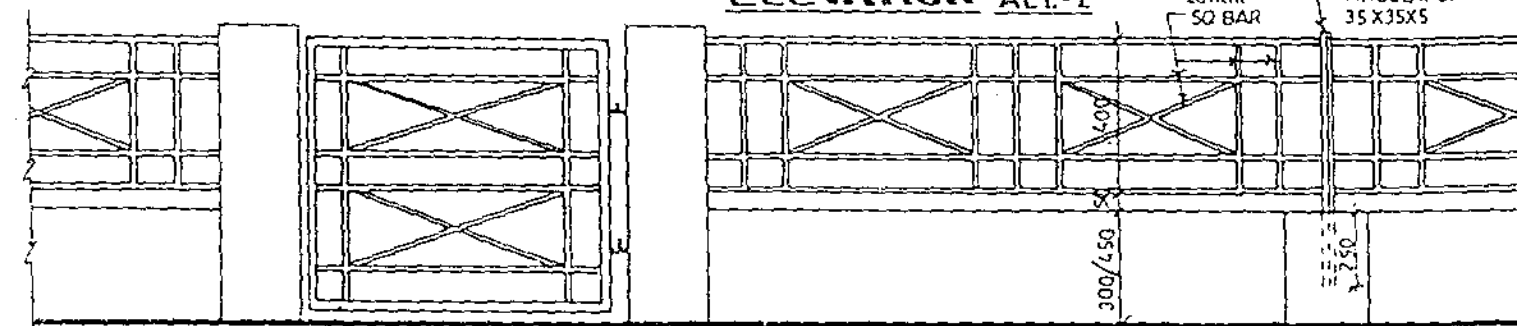

ELEVATION ALT-3

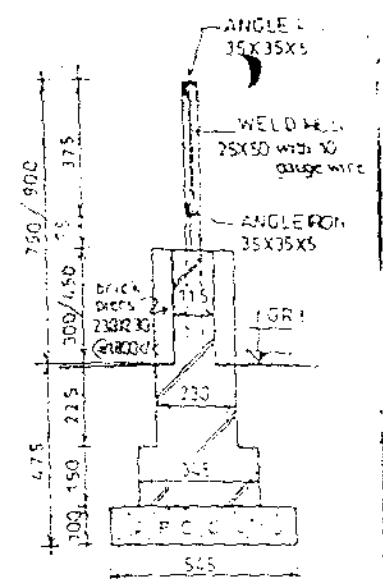

SECTION AT A-A

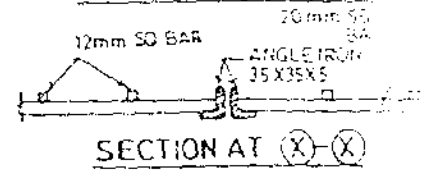

SECTION AT (X)-X

KENDRIYA VIDYALAYA SANGHAN
 SUGGESTIVE ONLY - COST SHOULD BE ECONOMICAL

DEMARCATON WALL

DRG NO. :- KVS-22	SCALE :- 1:20
SHEET NO. :-	DATE :-

47

SCHEMATIC DIAGRAM FOR WATER SUPPLY

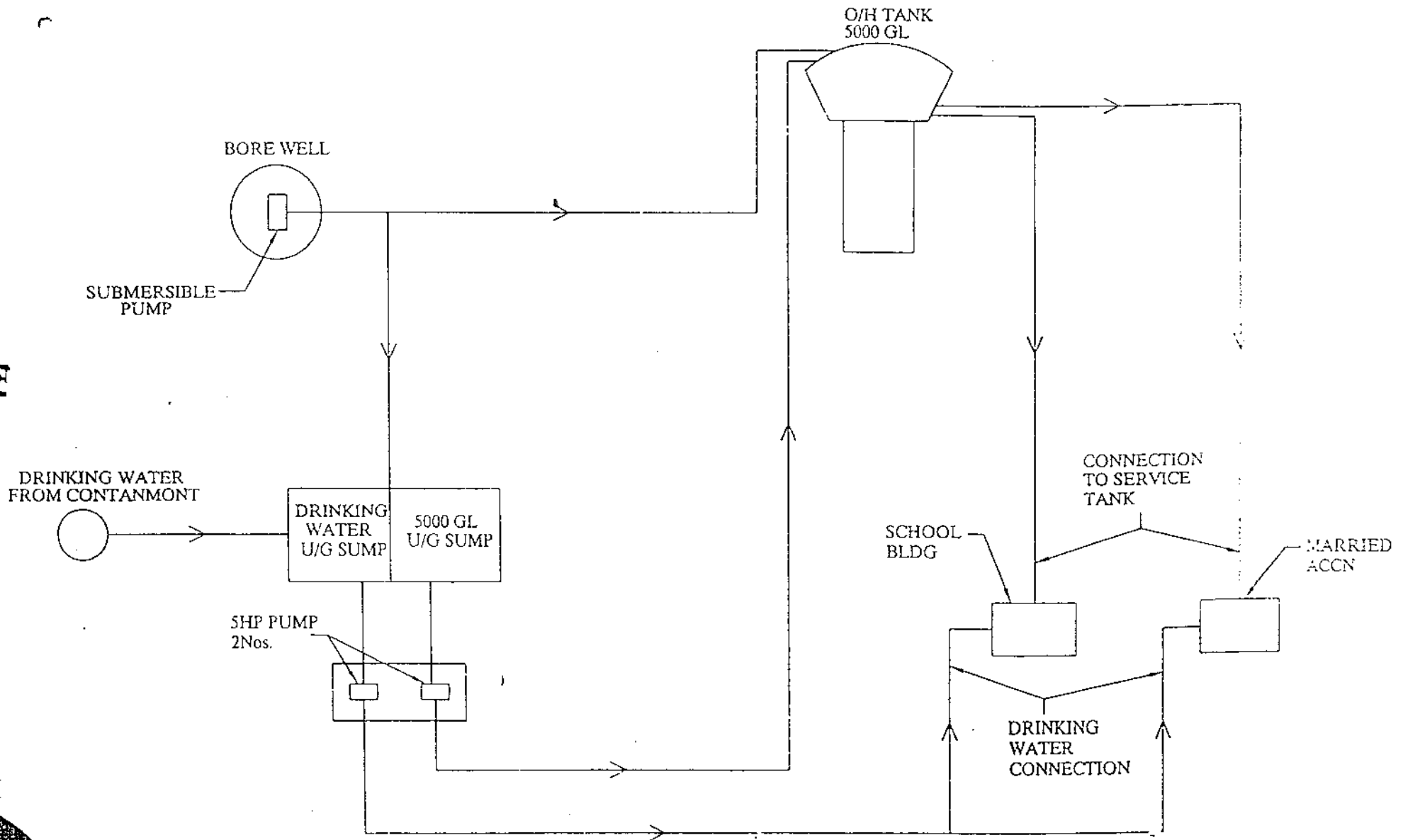

NOTES (1) OHT TO BE AVOIDED. DIRECT PUMPING FROM SUMP TO INDIVIDUAL SERVICE TANKS OF SCHOOL BUILDING/STAFF QUTS ETC PROVIDING GATE VALVES PREFERRED.
 (2) SERVICE DIAGRAM SHOWING DISTANCES TO BE PROVIDED TO PRINCIPAL FOR MAINTANENCE PURPOSE.

141

KVS-23

SCHEMATIC DIAGRAM FOR ELECTRIC SUPPLY

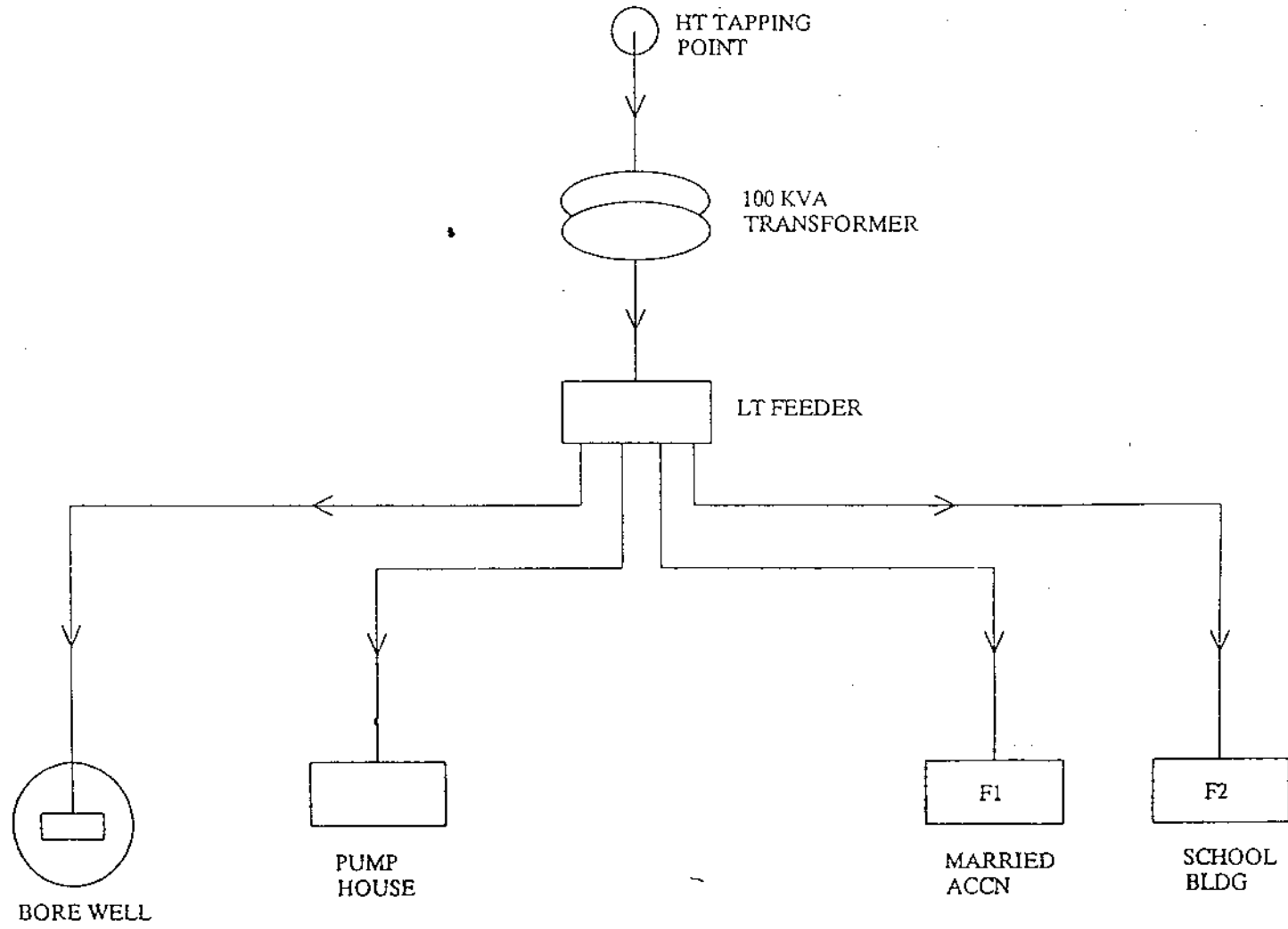

NOTE: DIAGRAM SHOWING DISTANCES TO BE PROVIDED TO PRINCIPAL FOR MAINTENANCE PURPOSE.

42

KVS-24

Abstract of Cost

Name of work :

S.No.	Item of work	Cost in Rs.
1.	Site clearance if any	Rs. _____
2.	Cost of school building portion including internal W/supply, sanitary installations and electric installations with wiring all fitting fixtures and other requirements	Rs. _____
(a)	Total covered area of building in all floors _____ sqmt	
(b)	Cost of building portion per sqmt (i.e. a/b) Rs. _____ per sqmt	
3.	(a)(b) (c) same as above for staff quarters (_____ units)	Rs. _____
4.	External services and site development works (based on economy and functional)	
(a)	Internal Roads/Paths/Culverts	Rs. _____
(b)	Water supply including Tube Well, pumphouse, pumps sump, O/H Tank	Rs. _____
(c)	Electrical supply including compound lighting	Rs. _____
(d)	Sewage disposal including septic tank, soakpits	Rs. _____
(e)	Area drainage	Rs. _____
(f)	Compound wall and gates (as per KVS norms)	Rs. _____
(g)	Cycle stand with tubular tress, AC sheet roof	Rs. _____
(h)	Levelling and dressing	Rs. _____
(i)	Retaining walls if any	Rs. _____
(j)	Sports facilities if any (please specify)	Rs. _____
(k)	Canteen, security hut	Rs. _____
(l)	Other items (please specify)	Rs. _____
	Total :-	Rs. _____
	Less rebate if any (-)	Rs. _____
	Contingencies @	Rs. _____
	Deptt. Charges @	Rs. _____
	Grant Total :-	Rs. _____

Signature of Competent Authority
of the agency with Name and
Designation

(stamp)

37

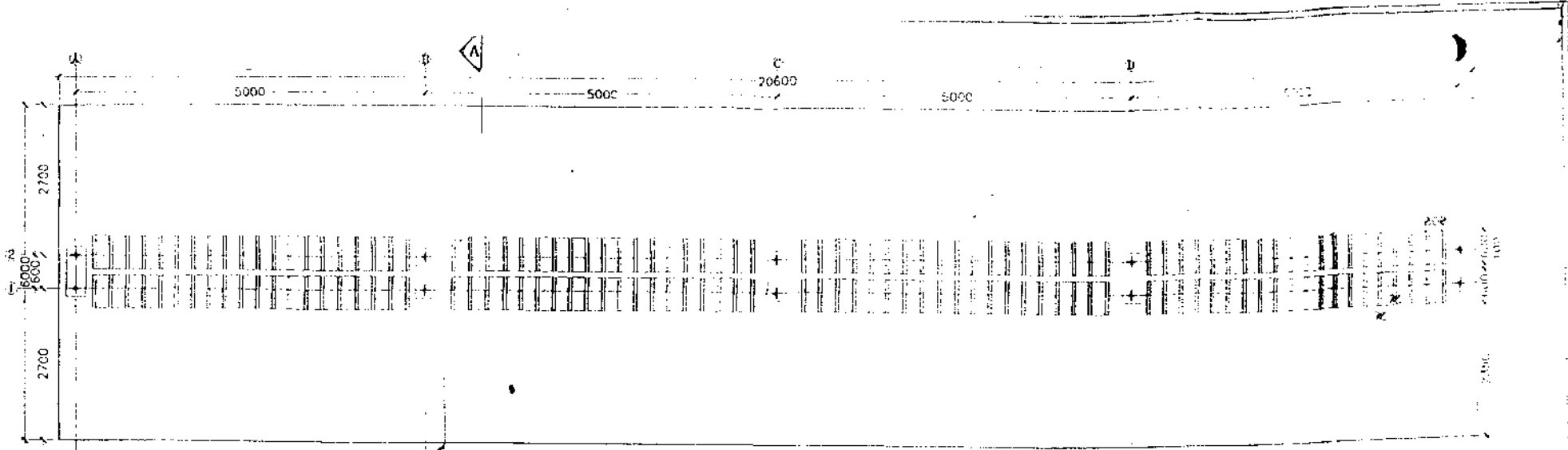

PLAN

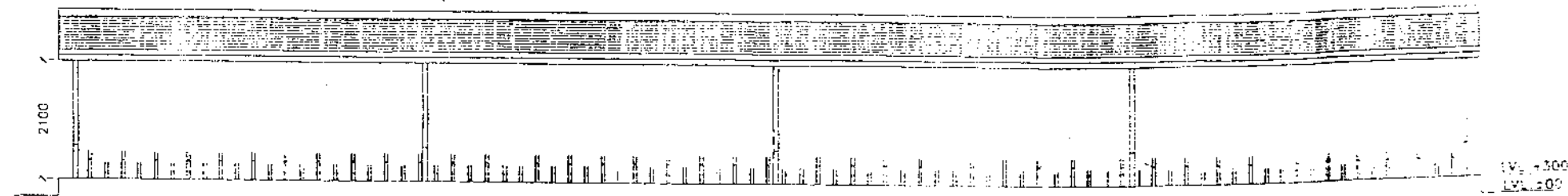

FRONT ELEVATION

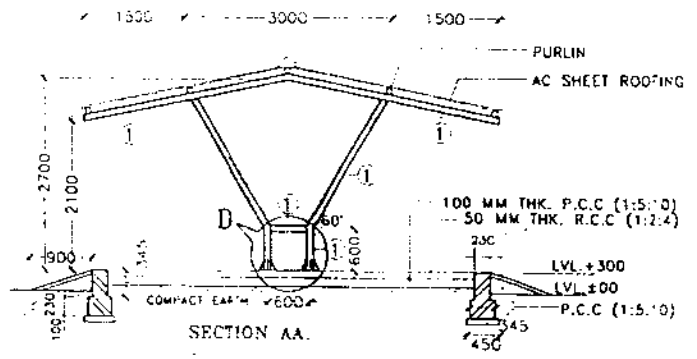

SECTION AA.

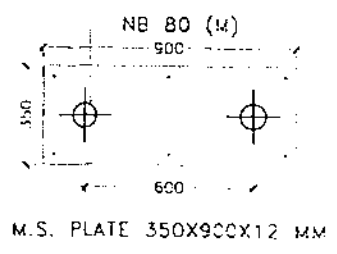

M.S. PLATE 350X900X12 MM

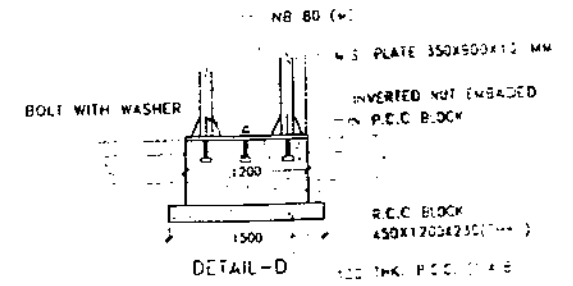

DETAIL - D

NOTE:

MAIN MEMBERS - 4 NB 80 (M)
 PURLIN - NB 65 (M)

PROJECT

KENDRIYA VIDYALAYA

TITLE
 CYCLE STAND
 SUGGESTIVE PLAN
 WITHOUT TRUSS

SCALE
 1:75
 DRAWN

DATE :
 DRG. NO.
 KVS-19